

# Lindab **Air filtration**

Technical Brochure





# Content

## Lindab Air Filtration Units

<b>Duct filter units</b> .....	<b>5</b>
• Duct pre-filter units KPF .....	5
• Duct HEPA filter units AKF .....	7
<b>Ceiling and wall HEPA filter units</b> .....	<b>12</b>
• Wall HEPA filter units AFH-1 .....	12
• Ceiling HEPA filter units with flat gasket AFV-8 .....	14
• Ceiling HEPA filter units with semicircular or U-shaped gasket AFV-8B .....	18
• Ceiling HEPA filter units with gel gasket AFV-8G .....	23
<b>Operating theatre ceilings</b> .....	<b>28</b>
• Operating theatre ceiling – perforated version DPS, DPS-N .....	28
• Operating theatre ceiling – textile version DSS, DSS-N .....	32
<b>Fluff separator</b> .....	<b>35</b>
• Fluff separator LN-1 .....	35
• Fluff separator LN-2 .....	37
<b>Filter grille</b> .....	<b>39</b>
• Filter grille FR .....	39
<b>Filters</b> .....	<b>41</b>
• EPA, HEPA, ULPA filters .....	42
• Bag filters .....	45
• Panel filters .....	46
<b>Accessories</b> .....	<b>48</b>

## Legend of symbols

<b>Al</b> Element is made of aluminium profiles, aluminium sheet or aluminium casting.	 Element is intended to be built in the ceiling or in the wall.	<b>F</b> Element is intended for air filtration. Filter is not included.
<b>St</b> Element is made of steel sheet.	 Element for air conditioning of rooms with floor to ceiling heights room up to 4 m.	<b>INOX</b> The element is made of stainless sheet steel AISI 304 / EN 1.4301.
<b>RAL 9010</b> Element is powder painted in standard RAL 9010 colour. Other desired colour is to be specified in the order.	<b>M</b> Element allows regulation by electric motor (Belimo electric motors).	
 Element is intended to be built in the wall.	<b>F EU...</b> Element is intended for air filtration. The filter of class ... is built in.	

# Overview

## Duct-filter units

Duct pre-filter units KPF are designed to clean the air in air conditioning and ventilating systems. Built-in filters are of Coarse 50% - ePM1 80% filter class according to ISO 16890 (old designation G3 -F9).

Duct HEPA filter unit AKF is being used in the network of inlet and outlet ducts used to supply or extract air from the rooms with highest demands regarding air cleanness.



KPF



AKF

## HEPA filter units

Wall HEPA filter units (AFH) and ceiling HEPA filter units AFV-8, AFV-8B, AFV-8G are used in both, supply and exhaust air ventilation and air-conditioning installations, which require maximal cleanness of the air. Built-in HEPA filters are of E10 to H14 class.

Ceiling HEPA filter units types AFV-8G have a special washer frame for attachment the filter via gel (liquid) gasket. The units guarantee absolute sit tightness for filters up to class U16.

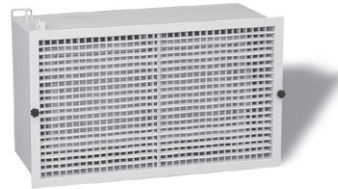

AFH-1



AFV-8

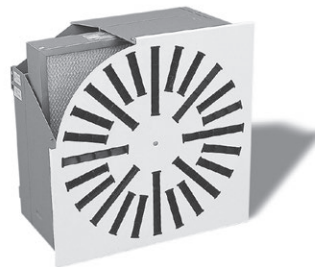

AFV-8G



AFV-8B

## Operating theatre ceiling with HEPA filters

Supply ceilings with built-in HEPA filters of E10 to H14 class, are used for clean rooms where air cleanness as well as laminar air flow is required. They are constructed to be built in false ceilings of operation rooms, intensive care premises and other clean rooms.



DPS



DSS

## Fluff separator and filter grilles

Fluff separators LN and Filter grilles FR are applied in air exhaust from clean rooms. They are designed for wall mounting.



LN-1



LN-1



FR

# Duct pre-filter units KPF

## Application

Duct pre-filter units KPF are built in supply air installations before rooms, which demand higher air cleanliness. KPF units extend the service life of HEPA filters, because larger dirty particles are removed by pre-filters, which are built in the system before HEPA filters.

## Description

KPF unit comprises filter of B x H x L dimensions, filter frames and bag filters of Coarse 50% - ePM1 80% filter class according to ISO 16890 (old designation G3 to F9). Filter housing is made of sheet metal, air-tight welded according to DIN 1946 and coloured in RAL 9010. Housing is fitted with connections for measuring of pressure drop. Galvanized steel sheet KPF possible (not airtight).

## Installation

Basic frames are being fitted into the KPF units via the side opening. The procedure requires 1000 mm of free space (Fig. 1). KPF housing is fitted into the duct network via the self-locking flange.

## Accessories

See chapter Accessories.

## Technical data

See chapter filters, subchapter Bag filters.

## Filter lifetime

Filter pollution is controlled by means of a differential manometer. The connections for plastic tubes are already fitted on the duct pre-filter units KPF.

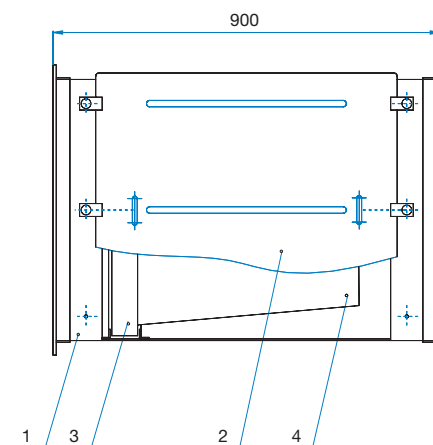

Fig. 1: Overview

1. Housing
2. Cover plate
3. Frame
4. Filter

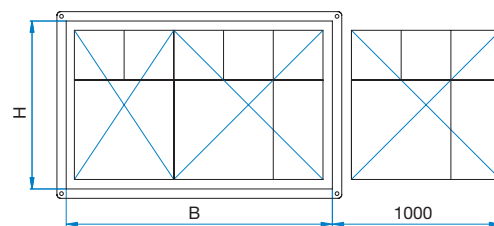
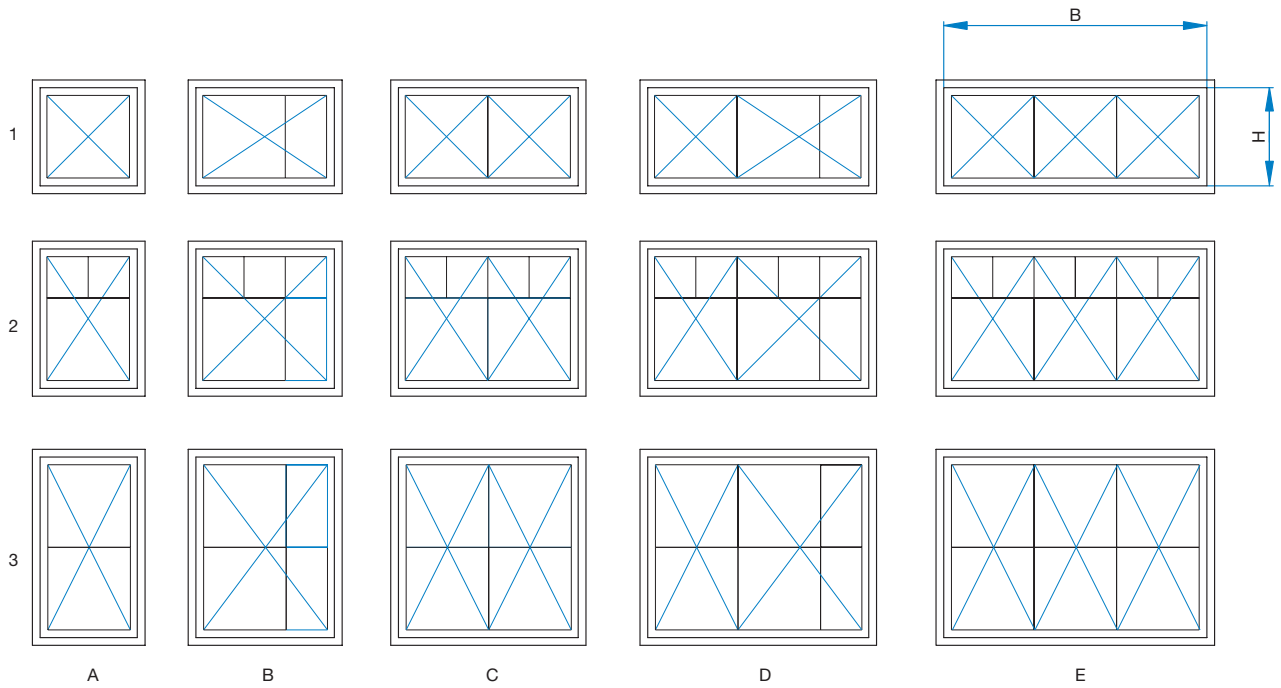

Table 1: Pre-filter unit size, quantity and size of bag filters

Size x	Weight (kg)	H (mm)	B (mm)	Bag filter, bag length 630 mm		
				592 x 592	287 x 592	87 x 287
1A	40	618	618	1	–	–
1B	52	618	925	1	1	–
1C	63	618	1232	2	–	–
1D	75	618	1539	2	1	–
1E	82	618	1846	3	–	–
2A	53	925	618	1	–	2
2B	68	925	925	1	1	3
2C	82	925	1232	2	–	4
2D	91	925	1539	2	1	5
2E	110	925	1846	3	–	6
3A	63	1232	618	2	–	–
3B	81	1232	925	2	2	–
3C	93	1232	1232	4	–	–
3D	110	1232	1539	4	2	–
3E	123	1232	1846	6	–	–

Fig. 2: Possible filter elements combinations



Ordering key

KPF-FV / G3 / 1A / POC

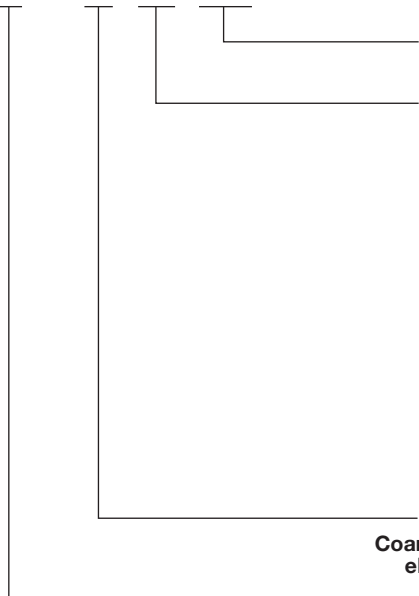

- POC** Galvanized steel
- RAL** Colored in RAL (standard color RAL 9010)
- 1A** 618 x 618 ... housing dimensions H x B
- 1B** 618 x 925
- 1C** 618 x 1232
- 1D** 618 x 1539
- 1E** 618 x 1846
- 2A** 925 x 618
- 2B** 925 x 925
- 2C** 925 x 1232
- 2D** 925 x 1539
- 2E** 925 x 1846
- 3A** 1232 x 618
- 3B** 1232 x 925
- 3C** 1232 x 1232
- 3D** 1232 x 1539
- 3E** 1232 x 1846
- G3-F9** Filter class acc. to EN 779:2012
- Coarse 50% - ePM1 80%** Filter class according to ISO 16890
- FV** Bag filter
- KA** Panel filters (on customer's request)

**Note:**  
 On request it is possible to produce also KPF units for other dimensions, types and classes of filters. Manometers have to be ordered separately.

# Duct HEPA filter units AKF

## Application

Duct HEPA filter unit AKF is being used in the network of inlet and outlet ducts used to supply or extract air from the rooms with highest demands regarding air cleanness. They can be installed as follows:

- air supply and extract in laboratories,
- air supply and extract in operation rooms, infection- and sterile departments,
- air supply in electronics, precision mechanics, chemistry, pharmaceuticals and food industry,
- air supply in film and audio tape industry,
- air supply and extract in nuclear technology etc.

## Description

AKF unit is made of filter housing, connection flanges and HEPA filter. Filter is fitted with washer of a rectangular cross-section. Filter housing is made of sheet metal air-tight welded according to DIN 1946 and coloured in RAL 9010. Two pressure gauge attachments for measuring of a pressure drop are incorporated into the housing.

## Bag-in/Bag-out (Safe filter replacement with the use of bags)

Bag-in/Bag-out is intended for filtration of air in processes during which hazardous or toxic substances are produced. The Bag-in/Bag-out system prevents any contact with the contents of a waste filter when replacing it. The installation of a pre-filter prolongs the life of a HEPA filter. The procedure of pre-filter replacement is the same as HEPA filter replacement.

## Installation and design executions

AKF housing are designed for installation of single AKF-I filter units. (Fig. 1, Fig. 2) as well as installation of several AKF-II units (Fig. 3, Fig. 4) into the duct system. To replace the filter, 700 mm of free space is required on the front side of the unit. AKF-II unit is made in several set-up combinations, determined by the position of connection flanges A1, A2, B1, B2 (Fig. 5, Fig. 6).

## Accessories

See chapter Accessories.

St  
RAL  
9010  
F

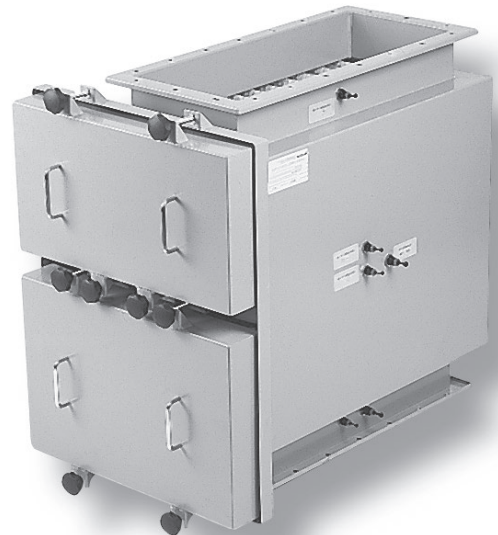

AKF-I



AKF-II



## AKF-I

Fig. 1

1. Filter housing
2. HEPA filter
3. Filter assembly levers
4. Bag-in/Bag-out spigot (only Bag-in/Bag-out version)
5. Connection (UPSTREAM) for scan test
6. Static pressure connection after filter –  $\Delta p$
7. Static pressure connection before filter +  $\Delta p$
8. HEPA filter cover
9. Screw for cover fixing

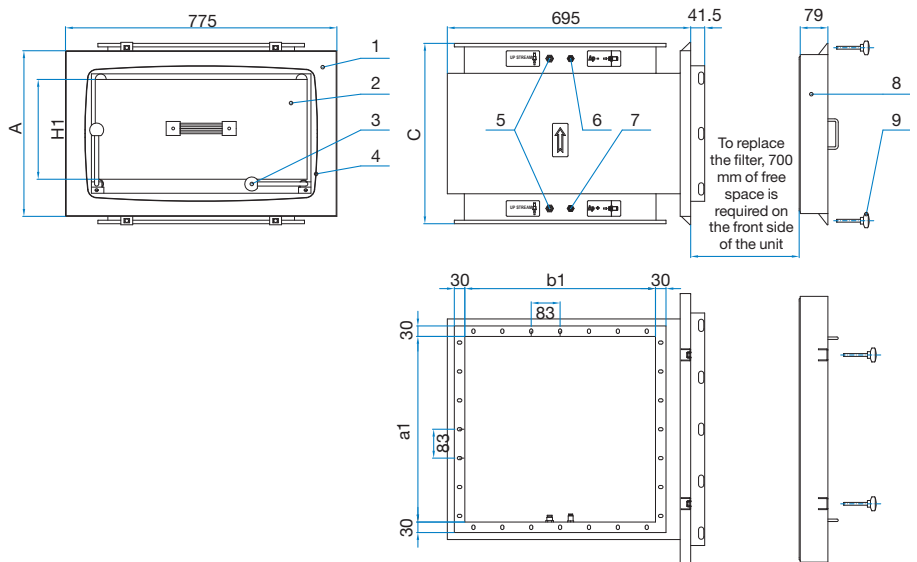

## AKF-I+KPF

Fig. 2

1. Filter housing
2. HEPA filter
3. Filter assembly levers
4. Bag-in/Bag-out spigot (only Bag-in/Bag-out version)
5. Connection (UPSTREAM) for scan test
6. Static pressure connection after filter –  $\Delta p$
7. Static pressure connection before filter +  $\Delta p$
8. HEPA filter cover
9. Screw for cover fixing
10. PRE-filter
11. PRE-filter cover

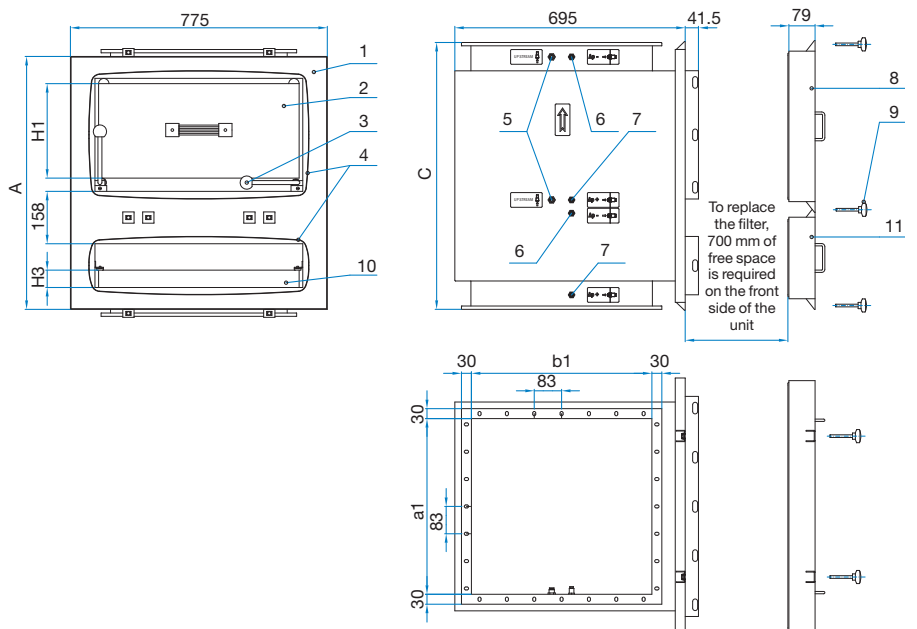

## Material and surface protection

Filter housing and filter covers are made from cold rolled steel.

On customer's request any other material can be chosen.

Filter housing and filter covers are powder coated in RAL 9010. On customer's request any other color in RAL can be chosen.

Table 1: Filter housing AKF-I dimensions and weight

Designation	H1	H3	A	C	a1	b1	Weight
HEPA filter 610 x 610 x 150	150	/	331	373	530	545	25.3 kg
HEPA filter 610 x 610 x 292	292	/	473	515	530	545	30.7 kg
HEPA filter 610 x 610 x 150 + PRE-filter 610 x 610 x 50	150	50	621	663	530	545	40.9 kg
HEPA filter 610 x 610 x 292 + PRE-filter 610 x 610 x 50	292	50	763	805	530	545	46.4 kg

Note: Deviation of weight is  $\pm 10\%$ .



# AKF-II (nominal size 1, 2, 3, 4)

## Material and surface protection

Fig. 3

- Connection ducts are made from cold rolled steel.
- Flat gasket is made from EPDM.
- Bases are made from square steel tubes.

On customer's request any other material can be chosen.

Filter housing, connection ducts, bases and filter covers are powder coated in RAL 9010. On customer's request any other color in RAL can be chosen.

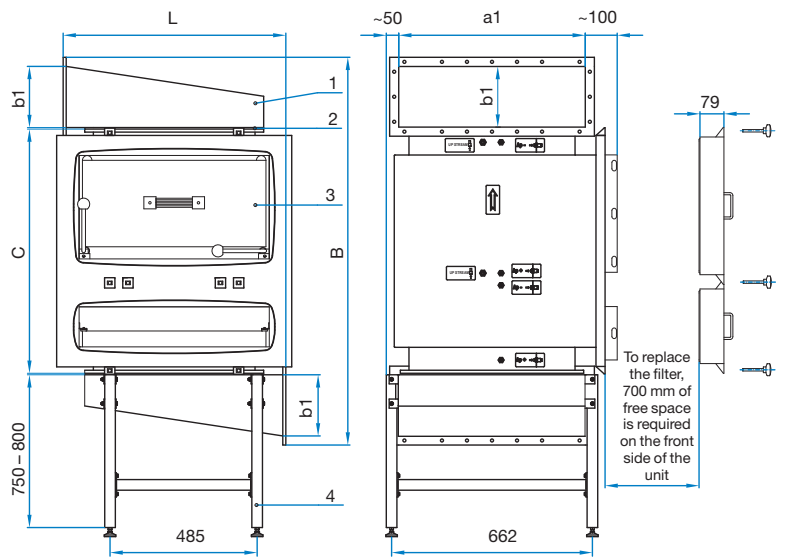
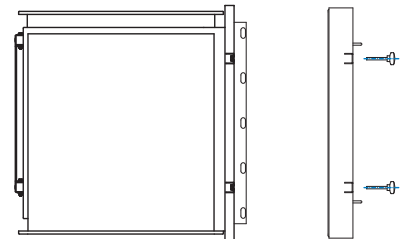

Fig. 3

1. Connection duct
2. Flat gasket
3. AKF-I (AKF-I+KPF)
4. Bases



## AKF-II (nominal size 2D, 4D, 6D, 8D)

Fig. 4

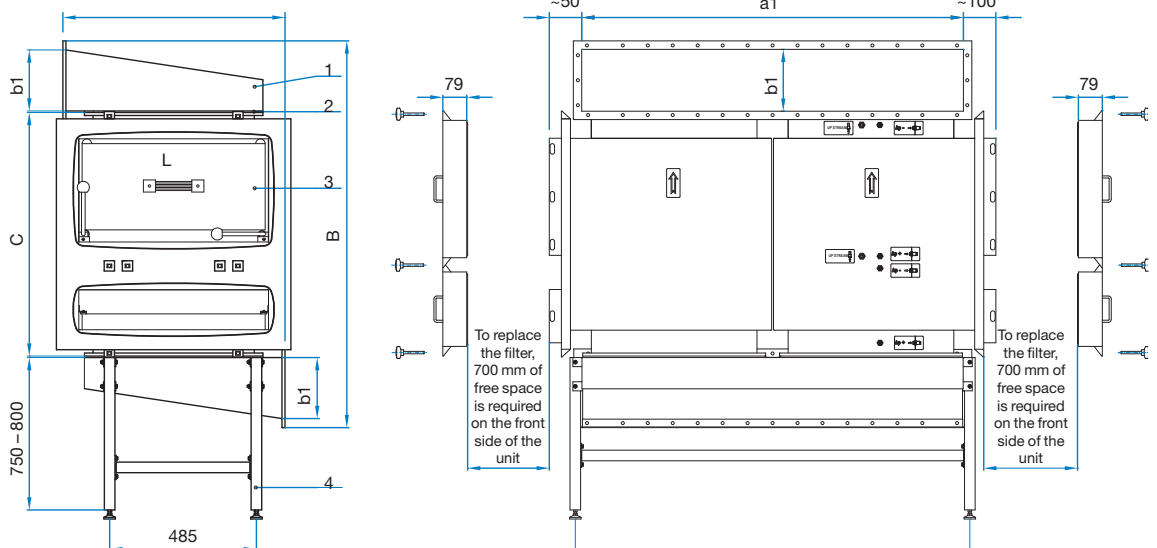

1. Connection duct
2. Flat gasket
3. AKF-I (AKF-I+KPF)
4. Bases

Table 2: Filter housing AKF-II dimension and weight table

Designation		AKF-II/1, 2, 3, 4				AKF-II/2D, 4D, 6D, 8D			
		1	2	3	4	2D	4D	6D	8D
Nominal size		1	2	3	4	1	2	3	4
No. of filters in length	$n_L$	1	2	3	4	1	2	3	4
No. of filters in width	$n_W$	/				2			
	L	734	1522	2312	3102	734	1522	2312	3102
Flange	a1	615				1257			
	b1	200	300	400	500	200	300	400	500
HEPA filter 610x610x150	B	846	1047	1247	1447	846	1047	1247	1447
	C	373				373			
	H1	150				150			
	weight	57 kg	123 kg	192 kg	266 kg	103 kg	217 kg	335 kg	457 kg
		B	1136	1337	1537	1737	1136	1337	1537
HEPA filter 610x610x150 + PRE-filter 610x610x50	C	663				663			
	H1	150				150			
	H3	50				50			
	weight	73 kg	154 kg	239 kg	328 kg	134 kg	279 kg	429 kg	582 kg
HEPA filter 610x610x292	B	988	1189	1389	1589	988	1189	1389	1589
	C	515				515			
	H1	292				292			
	weight	63 kg	134 kg	209 kg	288 kg	113 kg	239 kg	368 kg	501 kg
HEPA filter 610x610x292 + PRE-filter 610x610x50	B	1278	1479	1679	17879	1278	1479	1679	17879
	C	805				805			
	H1	292				292			
	H3	50				50			
	weight	78 kg	165 kg	256 kg	350 kg	145 kg	301 kg	473 kg	626 kg

Note: Deviation of weight is  $\pm 10\%$ .

AKF-II (connection flange dimensions)  
Fig. 5

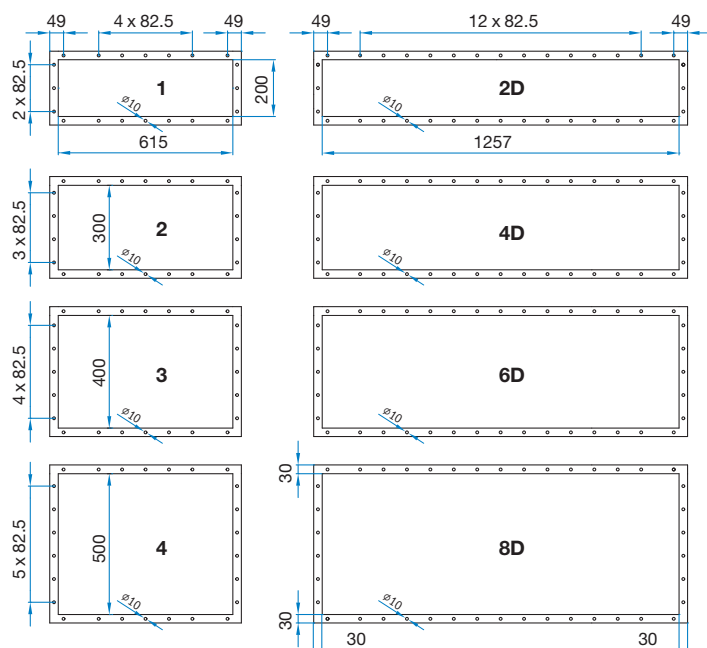

AKF-II (position of flange connections)  
Fig. 6

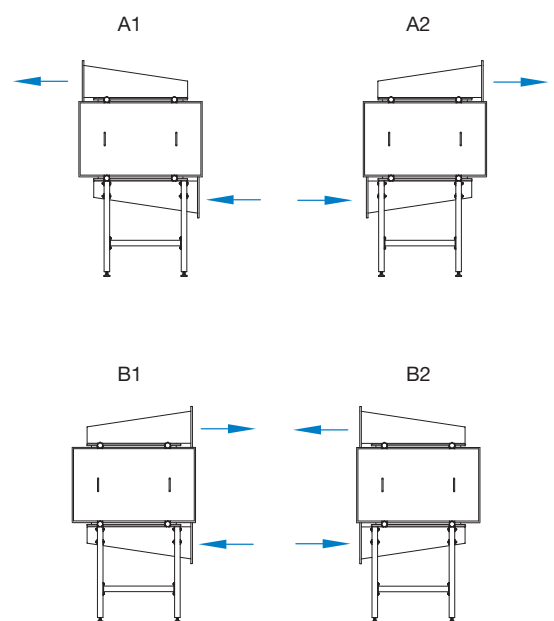

### Expected service life of HEPA filter and replacement

HEPA filter are constructed for single use only. Expected service life of filter depends on air flow volume, pressure drop and amount of dust particles. When air flow volume is reduced for 25 %, expected service life of HEPA filter doubles. Service life can be considerably increased with installation of pre-filter.

HEPA filter pollution is controlled by means of a differential manometer which can be fitted on the housing. Connections for plastic tubes are fitted on AKF housing.

When the pressure drop has reached double its initial value, it is recommended to replace the HEPA filter. When replacing the AKF filter, remove cover, release the lever and finally remove the frame with used HEPA filter. When installing the new filter, use the above instructions in opposite order.

In case of replacement of filters using bags (bag-in, bag-out system), the procedure is the same with the exception of a bag attached to the extension. The waste filter is removed into a bag, which has been attached to the extension since the last replacement. The bag is then hermetically closed so that after the separation of the part of the bag with the filter, a part of the bag remains on the extension, hermetically closed as well. A new filter is put in a bag and then placed over the remaining part closing the duct. Upon the placement of the new bag, the remaining part of the old bag is first removed into the new bag. A new filter is installed from the new bag. The bags are attached to the extension by means of a rubber collar.

### Ordering key

#### AKF-I / 1 / H1 / H3 / BIBO

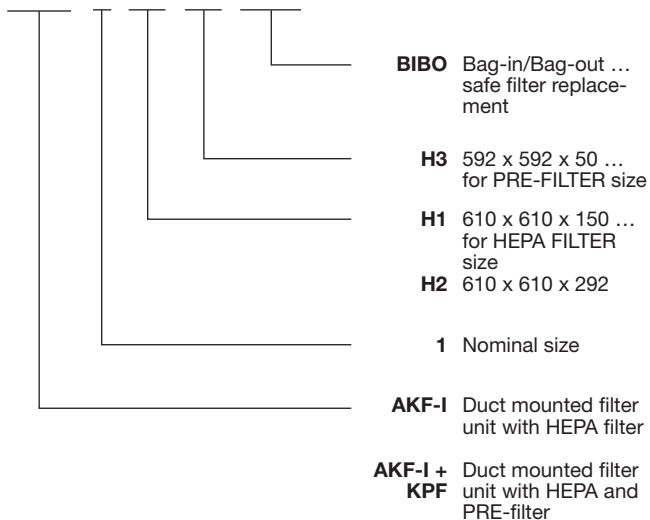

**Note:**

- Filter is not included in AKF housing and must be ordered separately.
- On request it is possible to produce also AKF unit for other sizes of HEPA filters.
- Manometers have to be ordered separately.

### Ordering key

#### AKF-II / 1 / H1 / H3 / A1 / BIBO

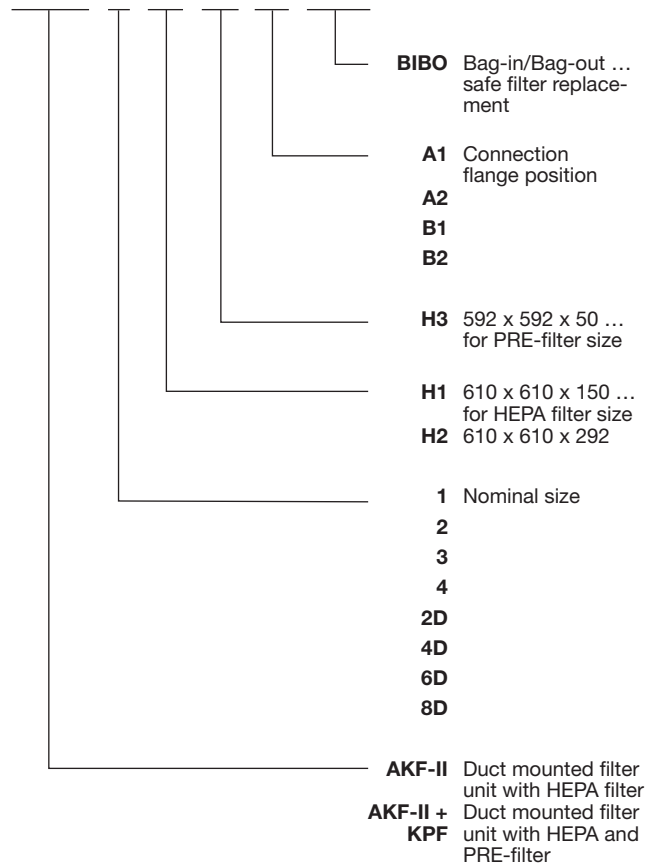

**Note:**

- Filter is not included in AKF housing and must be ordered separately.
- On request it is possible to produce also AKF unit for other sizes of HEPA filters.
- Manometers have to be ordered separately.

# Wall HEPA filter units AFH-1

## Application

Wall HEPA filter unit AFH-1 is being used in the network of inlet and outlet ducts used to supply or extract air from the rooms with highest demands regarding air cleanliness. HEPA filter is fitted with a washer of a rectangular cross section. With the AFH-1/3 version, the seal may also be semi-circular. They can be installed as follows:

- air supply and extract in laboratories,
- air supply and extract in operating rooms, infection- and sterile departments,
- air supply in electronics, precision mechanics, chemistry, pharmaceuticals and food industry,
- air supply in film and audio tape industry,
- air supply and extract in nuclear technology etc.

## Description

AFH-1 unit is made of filter housing, two-row steel grille SD-11 and HEPA filter. Filter housing made of sheet steel is air tight welded according to DIN 1946 and coloured in RAL 9010. Grille is made of cold-drawn strip steel and coloured in RAL 9010. Grille is fastened to the housing via the nuts which can be tightened or unscrewed manually. AFH-1 unit is fitted with special sealing frame for sit-tightness test.

On request the grille is also available stainless steel (SSD-11) version.

## Design variations

The type of sealing frame determines three filter unit types and two HEPA filter sizes (AFH-1/1 and AFH-1/3, size 1 and 2).

## Installation

AFH-1 unit is designed for installation in the walls of the clean rooms.

## Accessories

See chapter Accessories.

## Technical data

Size of grille regarding the size of housing and HEPA filter is specified in table 2. Technical data for the SD-11 grille are stated in the catalogue.

Size and flow characteristics of HEPA filters installed in AFH-1 are specified in chapter Filters.

## Expected service life of HEPA filter and replacement

HEPA filters are constructed for single use only. Expected service life of filter depends on air flow volume, pressure drop and amount of dust particles. When air flow volume is reduced for 25 %, expected service life of HEPA filter doubles. Service life can be considerably increased with installation of pre-filter.

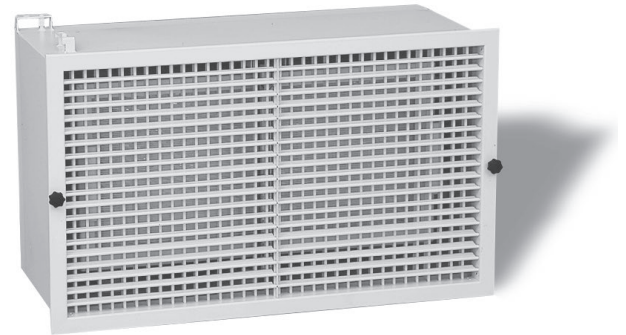
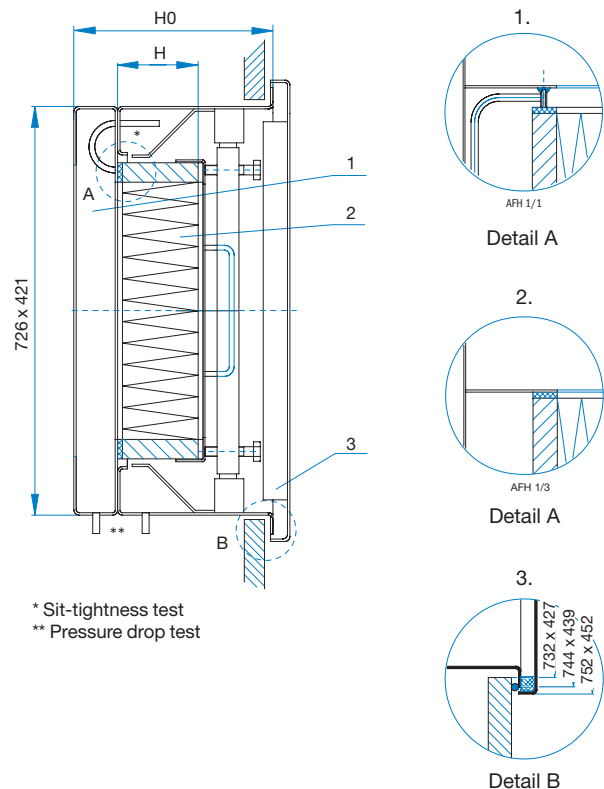

Table 1: Overview

HEPA filter unit	Application	Class
AFH - 1/1	Sit-tightness and SCAN test	E12, H13, H14
AFH - 1/3	SCAN test	E10, E11

Fig. 1: Overview



1. Housing
2. HEPA filter (with flat gasket)
3. Grille

HEPA filter pollution can be controlled by means of a differential manometer which can be fitted on the housing.

Connections for plastic tubes are fitted on AFH-1 housings.

When the pressure drop has reached double its initial value, it is recommended to replace the HEPA filter. When replacing the AFH-1 filter, remove grille and screws on the holding bar and then remove the bar together with used filter. When installing the new filter use the above instructions in opposite order. The sit tightness is to be tested according to DIN 1946, chapter 4. The permeability at the test pressure of 2000 Pa should not exceed the values stated in standard.

The checking is carried out with sit-tightness measuring device.

Connection flange

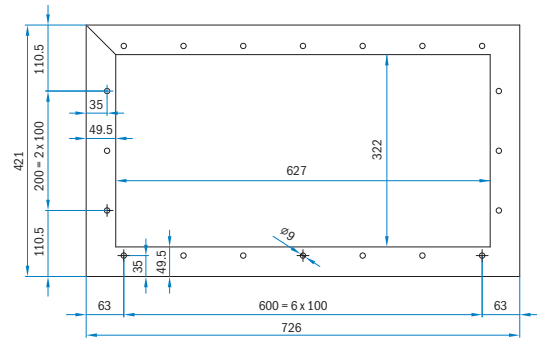

Table 2: Technical data

Nominal size	HEPA filter	H0	H1	Grile SD-11	weight AFH-1/1 *	weight AFH-1/3 *
1	305 x 610 x 150	338	150	725 x 425	23,7 kg	21,7 kg
2	305 x 610 x 292	480	292	725 x 425	27,6 kg	25,5 kg

Note: Deviation of weight is ±10 %.

## Ordering key

### AFH-1 / 1 Size 1, SD-11

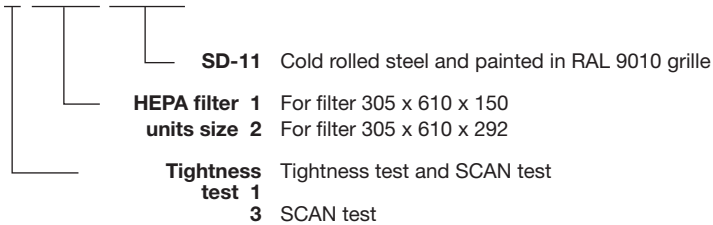

Note:  
Filter is not included and must be ordered separately.

# Ceiling HEPA filter units with flat gasket AFV-8

## Application

Ceiling HEPA filter units AFV-8 are used in supply or extract air applications in air conditioning and ventilating installations of the rooms with highest demands regarding air cleanliness. They can be installed as follows:

- Air supply and extract in laboratories,
- Air supply and extract in operating rooms, infection- and sterile departments,
- Air supply in electronics, precision mechanics, chemistry, pharmaceuticals and food industry,
- Air supply in film and audio tape industry,
- Air supply and extract in nuclear technology etc.

## Description

Ceiling HEPA filter unit AFV-8 is made of filter housing, standard diffusers KD-1A, KD-6, OD-8KR or OD-9KK and HEPA filter. Filter is fitted with washer of a rectangular cross-section. Housing of sheet steel is air tight welded according to DIN 1946 and coloured in RAL 9010. Two pressure gauge attachments for measuring of a pressure drop are incorporated into the housing. Diffusers made of sheet steel are coloured in white (RAL 9010). AFV-8 housing has a special sealing frame designed to perform sit tightness test.

## Installation

AFV-8 unit is constructed to fit into suspended ceilings.

## Types

The following HEPA filter units AFV-8 are possible:

- With circular side entry spigot (AFV-8 RS) (fig. 2, table 1).
- With circular top entry spigot (AFV-8 RV) (fig. 3, table 2).
- With rectangular side entry spigot (AFV-8 KS) (fig. 4, table 3).

## Accessories

See chapter Accessories.

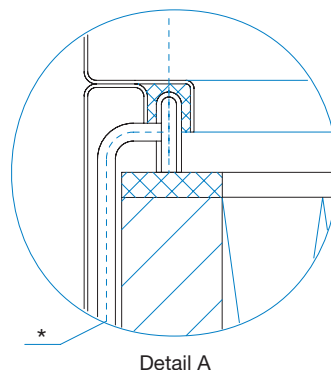
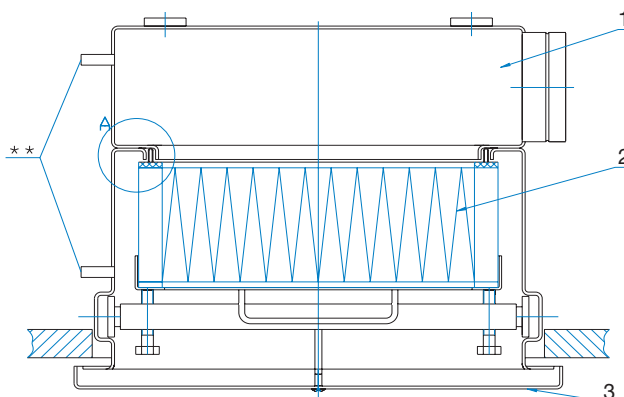

Fig. 1: Overview



\* Sit tightness test  
 \*\* Pressure drop test

### AFV-8/RS with circular side entry spigot

Fig. 2

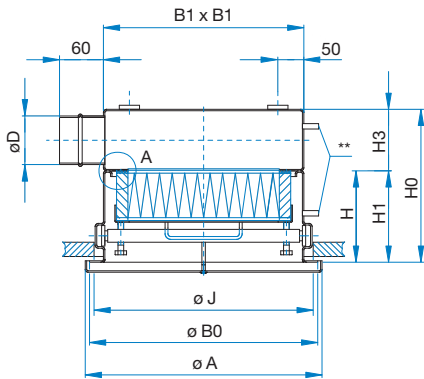

Table 1: Dimensions of AFV-8/RS

Size	HEPA filter	øD	A	B0	B1	J	H0	H1	H3
1	305 x 305 x 150	148	355	348	319	324	450	270	178
2A	457 x 457 x 78	198	507	500	471	476	428	198	230
2B	457 x 457 x 150	198	507	500	471	476	500	270	230
3	610 x 610 x 78	198	660	653	624	629	428	198	230
4	610 x 610 x 150	298	660	653	624	629	600	270	330
5	610 x 610 x 292	348	660	653	624	629	792	412	378

### AFV-8/RV circular top entry spigot

Fig. 3

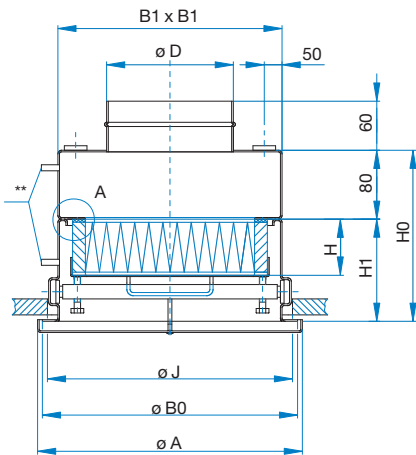

Table 2: Dimensions of AFV-8/RV

Size	HEPA filter	øD	A	B0	B1	J	H0	H1
1	305 x 305 x 150	148	355	348	319	324	350	270
2A	457 x 457 x 78	198	507	500	471	476	278	198
2B	457 x 457 x 150	198	507	500	471	629	350	270
3	610 x 610 x 78	198	660	653	624	629	278	198
4	610 x 610 x 150	298	660	653	624	629	350	270
5	610 x 610 x 292	348	660	653	624	629	492	412

### AFV-8/KS rectangular side entry spigot

Fig. 4

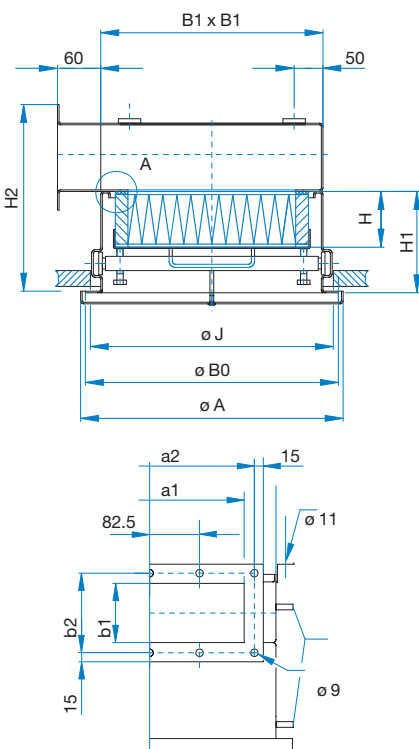

Table 3: Dimensions of AFV-8/KS

Size	HEPA filter	A	B0	B1	J	H1	H2	a1	b1	a2	b2
1	305 x 305 x 150	355	348	319	324	270	400	250	100	285	136
2A	457 x 457 x 78	507	500	471	476	198	328	400	100	435	131
2B	457 x 457 x 150	507	500	471	476	270	400	400	100	435	136
3	610 x 610 x 78	660	653	624	629	198	328	500	100	535	136
4	610 x 610 x 150	660	653	624	629	270	460	560	160	595	196
5	610 x 610 x 292	660	653	624	629	412	642	560	200	595	236



### Diffuser types

- Sheet steel painted in RAL
- Stainless sheet steel (except KD-1)
- Standard deflector colours are black

### Technical data

Possible combinations of diffuser size regarding the size of housing and HEPA filter is specified in table 4. Mounting dimensions of diffusers to be installed in AFV-8 are specified in tables 1, 2 and 3 and in column A.

### Technical data of HEPA filters

Size and flow characteristics of HEPA filters installed in AFV-8 are specified in Filter chapter.

KD-1A

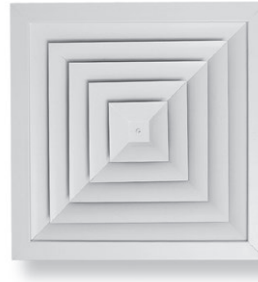

KD-6

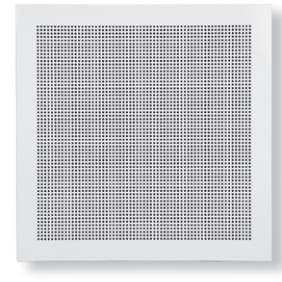

OD-8KR

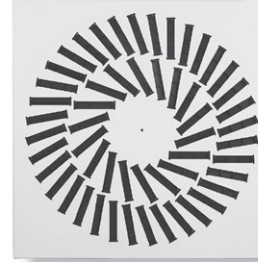

OD-9KK

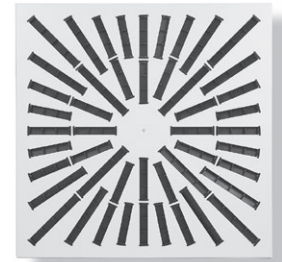

**Table 4:** Filter and front plate combinations

Filter unit size	HEPA filter	A*	Diffuser size**			
			KD-1A	KD-6	OD-8KR	OD-9KK
1	305 x 305 x 150	355 x 355	1,2,3	√	-	400
2A	457 x 457 x 78	507 x 507	3,4	√	500/16	500
2B	457 x 457 x 150	507 x 507	3,4	√	500/16	500
3	610 x 610 x 78	660 x 660	5,6,7,8	√	600/24, 625/54	600
4	610 x 610 x 150	660 x 660	7,8	√	600/24, 625/54	600
5	610 x 610 x 292	660 x 660	7,8	√	600/24, 625/54	600

\*Outer dimension of diffuser front plate.

### AFV-8 with airtight damper DTU

#### Application

On the ceiling HEPA filter unit AFV-8 a shut-off damper DTU is installed in the housing connection. The shut-off damper DTU conforms to the EN 1751 class 4 standard requirements.

The advantage of such a combination of an HEPA filter housing and a shut-off damper is the ability to close the shut-off damper during the filter exchange and thereby to prevent room air pollution. Upon the completion of the filter exchange, the shut-off damper is reopened. Such a filter exchange procedure eliminates the need to disinfect the room, which is mandatory in the case of exchanging the filter without shutting-off the inlet of non-filtered air.

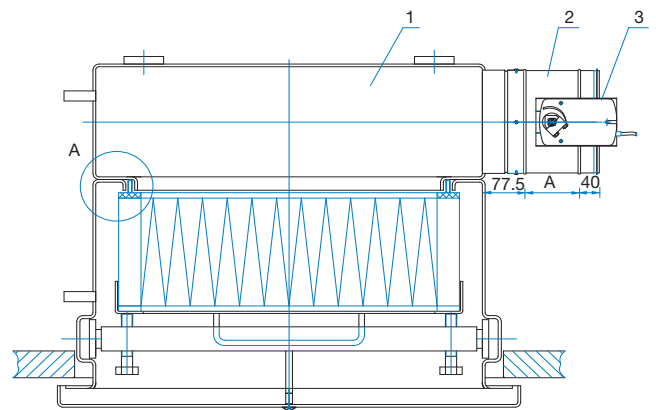

**Fig. 5**

1. AFV-8/RS, RV
2. DTU
3. Electric motor (with spring LF24, LF230)

## Description

On the connection of the standard ceiling HEPA filter unit AFV-8, a galvanised sheet steel shut-off damper is mounted by means of four screws. The damper may be controlled either manually or by means of an electric motor.

## Expected service life of HEPA filter and replacement:

HEPA filter are constructed for single use only. Expected service life of filter depends on air flow volume, pressure drop and amount of dust particles. When air flow volume is reduced for 25 %, expected service life of HEPA filter doubles. Service life can be considerably increased with installation of pre-filter. The dirtiness of the filter is controlled by the means of differential manometer. Connections for plastic tubes are fitted on AKF housing.

The initial pressure drop is specified in Filter chapter. When the pressure drop has reached double its initial value, it is recommended to replace the HEPA filter. When replacing the AFV-8 filter, remove diffuser and screws on the holding bar and then remove the bar together with used filter. When installing the new filter use the above instructions in opposite order. The sit tightness is to be tested according to DIN 1946 standard, chapter 4. The permeability at the test pressure of 2000 Pa should not exceed the values stated in standard. The checking is carried out with sit-tightness measuring device.

**Table 5:** Dimensions of AFV-8 with shut-off damper DTU

AFV-8	HEPA filter	DTU		
		φD	size	A
1	305 x 305 x 150	148	150	100
2A	457 x 457 x 78	198	200	130
2B	457 x 457 x 150	198	200	130
3	610 x 610 x 78	198	200	130
4	610 x 610 x 150	298	300	130
5	610 x 610 x 292	348	350	130

## Ordering key

### AFV-8 / RS1 / R / KD-6 / RAL

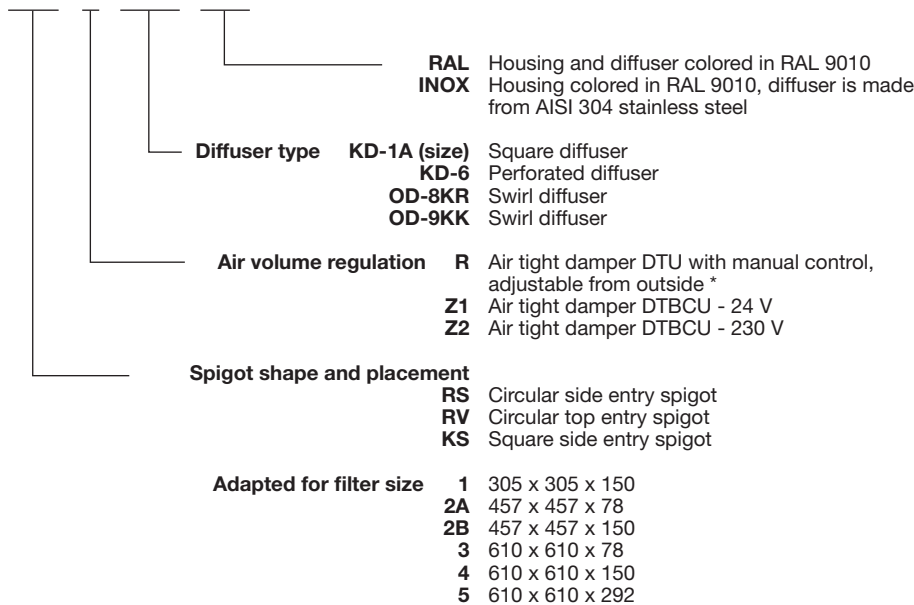

**Note:**

Filter is not included and must be ordered separately.

\* Air tight damper DTU is possible only with version RS and RV.

# Ceiling HEPA filter units with semicircular or U-shaped gasket AFV-8B



- St
- RAL 9010
- F
- M
- ▲

AFV-8B/F/\_R\_-S (side entry spigot)

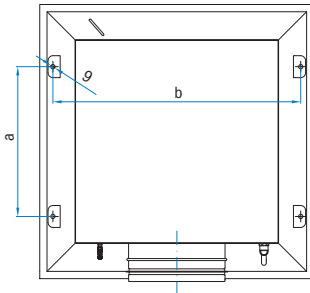
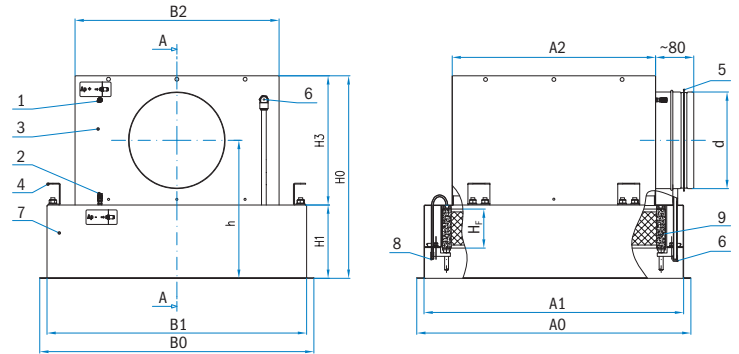

## Description

- General description: air supply for highest standards of air purity,
- Filter: E10...H14 class (EN 1822:2009),
- Front plate: KD-1A, KD-6, OD-5, OD-9KK, OD-15KK, SR-4,
- Dry gasket: (PO) semicircular (foam) or (U) U-shaped profile,
- Suitable for: air supply in laboratories, infection and sterile departments, electronics, precision mechanics, pharmaceuticals, chemistry, food, film and audio tape industry.

## Material and surface protection

- Filter housing, diffuser and spigot connection housing is made from cold rolled steel,
- Holding brackets are made from stainless steel,
- Filter holders are made from galvanized engineering steel.

On customer's request the filter units can be made from stainless steel.

Filter housing and front plate are powder coated in RAL 9010. On customer's request any other color in RAL can be chosen.

## Accessories

See chapter Accessories.

AFV-8B/F/\_R\_-V (top entry spigot)

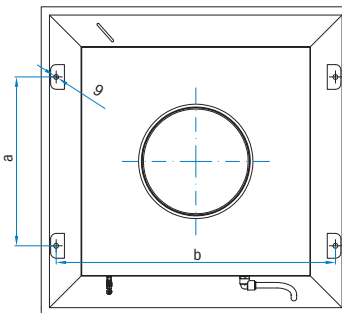
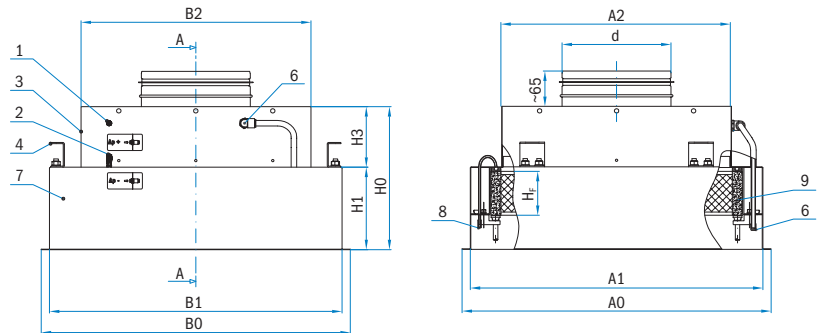

1. Static pressure connection in front of filter +  $\Delta p$
2. Static pressure connection after filter -  $\Delta p$
3. Spigot connection housing
4. "O" hangers or "T" traverse
5. Rubber lip sealing
6. Connection (UPSTREAM) for scan test
7. Filter housing
8. Connection for filter tightness test (DIN 1946-4)
9. Filter.

**Table 1:** Filter housing dimension and weight table

Filter dimension				Spigot			Plenum box							AFV-8B/F_/R_-S				AFV-8B/F_/R_-V						
				H <sub>F</sub>		ød	A0	A1	A2	a	B0	B1	B2	b	h	H1	H3	H0	Weight [kg]	H1	H3	H0	Weight [kg]	
F10	305	x	305	x	69-80	R4	158	410	380	265	155	410	380	265	356	263	150	225	375	6.1	150	110	260	5.2
F20	305	x	610	x	69-80	R5	198	410	380	265	155	715	685	570	661	283	150	265	415	9.6	150	110	260	7.5
F30	457	x	457	x	69-80	R5	198	562	532	417	307	562	532	417	508	283	150	265	415	9.8	150	110	260	7.7
F40	535	x	535	x	69-80	R6	248	640	610	495	385	640	610	495	586	308	150	315	465	12.3	150	110	260	9.1
F50	610	x	610	x	69-80	R6	248	715	685	570	460	715	685	570	661	308	150	315	465	14.3	150	110	260	10.6
F60	610	x	915	x	69-80	R8	313	715	685	570	460	1020	990	875	966	340	150	380	530	19.8	150	110	260	13.6
F70	610	x	1220	x	69-80	R9	353	715	685	570	460	1325	1295	1180	1271	360	150	420	570	25.0	150	110	260	16.6

**Note:**

- Total weight = weight of front plate + weight of housing + weight of filter.
- Deviation of weight is ±10 %.

**Detail: Filter gasket type**

(U) U-shaped profile:

- It is considered as dry gasket
- Filter tightness test (DIN 1946-4): YES
- Measuring tube size ø4 mm on housing allows pressure tapping for filter tightness test (position 8)

(PO) Semicircular shaped profile:

- It is considered as dry gasket
- Filter tightness test (DIN 1946-4): NO
- Housing doesn't have measuring tube for pressure tapping for filter tightness test

**Detail: Filter and front plate fixing**

Bottom plate is mounted with screws to movable nuts (position 10) on filter housing. Filter is fixed in place with pressure screw on filter holders (position 11 and 17). Height of filter can be from 69 up to 80 mm.

**Detail: UPSTREAM connection for scan test**

Housing has UPSTREAM connection (position 6) size ø8 mm for scan test. This way you can taper concentration of MPPS size aerosol on dirty side of filter and confirm filter efficiency and also filter housing tightness.

It can also be used to monitor static pressure before filter + Δp.

**Fig. 1**

**Detail:** Filter gasket type

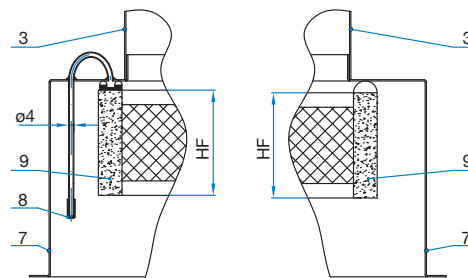

**Detail:** Filter and bottom plate fixing

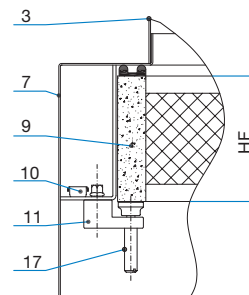

**Detail:** UPSTREAM connection for scan test

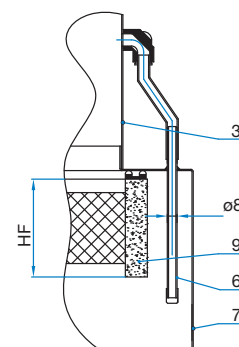

- 3. Spigot connection housing
- 6. Connection UPSTREAM for scan test
- 7. Filter housing
- 8. Connection for filter tightness test (DIN 1946-4)
- 9. Filter
- 10. Bottom plate nuts
- 11. Filter holders

**Installation: “O” hangers**

When using “O” hangers, first step is to mount four threaded rods size 8 mm (position 12) to fixed ceiling according to dimension a and b from Table 1 in place of AFV-8B final position. Second step is to make B1+10 / A1+10 size hole in suspended ceiling to fit filter housing (position 7). Final step is to place sealant on interface of filter housing and suspended ceiling and secure it in place with nut (position 13) and spring washer (position 14) on to threaded rod.

**Installation: “T” traverse**

When using “T” traverse, first step is to make B1+10 / A1+10 size hole in suspended ceiling to fit filter housing (position 7). Then place sealant on interface of filter housing and suspended ceiling, attach traverse (position 16) on filter housing and secure it to the suspended ceiling. Thickness of suspended ceiling can be from 15 to 50 mm).

Fig. 2

Installation: “O” hangers

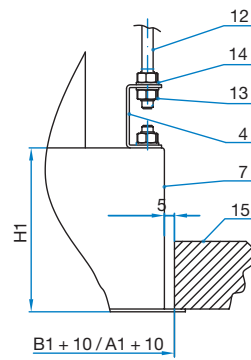

Installation: “T” traverse

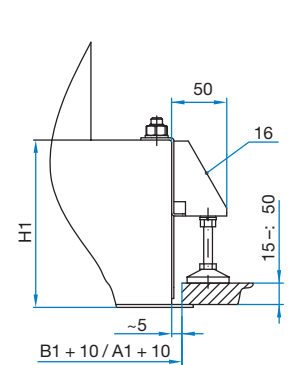

- 4. “O” hangers
- 7. Filter housing
- 11. Filter holders
- 12. Threaded rod size 8 mm
- 13. Nut for threaded rod
- 14. Spring washer for threaded rod
- 15. Suspended ceiling
- 16. “T” traverse

**Regulation:**

First you need to install filter and lock it into place. Then you have to loose screw for hatch blocker (position 5) and move regulation hatch (position 1) into place with regulation axis (position 3). Then you have to tighten screw for hatch blocker (position 5) and install bottom plate.

**Housing size:**

Standard air volume regulation can be chosen only for filter size F10, F20, F30, F40, F50.

**Material and surface protection:**

- filter housing, bottom plate and spigot connection housing is made from cold rolled steel,
- holding brackets and regulation axis are made from stainless steel,
- detachable regulation hatch is made from galvanized sheet steel,
- filter holders are made from galvanized engineering steel.

On customer’s request any other material can be chosen.

Filter housing and bottom plate are powder coated in RAL 9010, 30 % gloss. On customer’s request any other color in RAL can be chosen.

**Dimensions and weight 1,2**

- 1) for whole weight sum weight of bottom plate, weight of housing, weight of filter and additional weight for volume regulation shown on table 2
- 2) deviation of weight is ±10 %

Fig. 3

Detail: Side entry spigot with air volume regulator (not airtight)

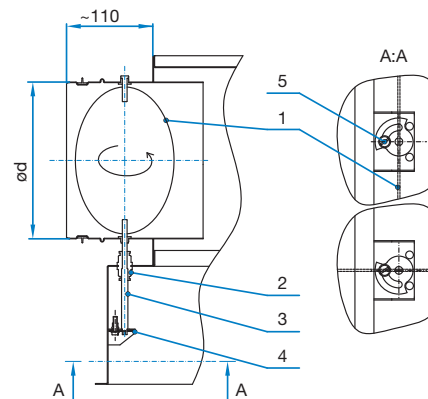





- 1. Detachable regulation hatch
- 2. Air tight fittings
- 3. Regulation axis (0° to 90°)
- 4. Hatch blocker
- 5. Screw for hatch blocker

Table 2: Additional weight for air volume regulator

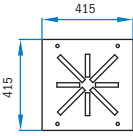
Spigot		
	ød	Weight [kg]
R4	158	0.3
R5	198	0.4
R6	248	0.5

**Filter and front plate combinations**

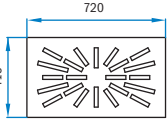
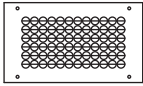
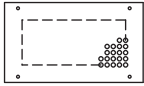
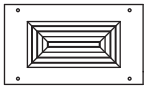
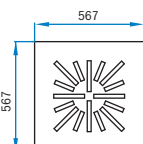
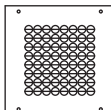
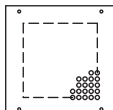
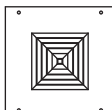
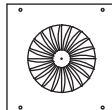
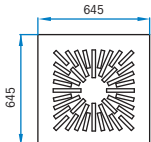
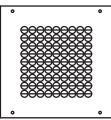
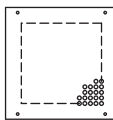
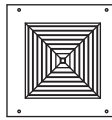
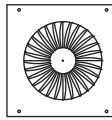
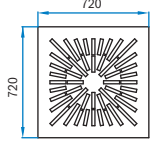
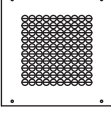
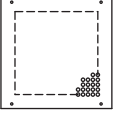
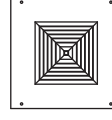
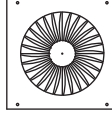
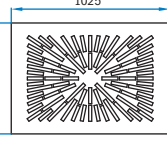
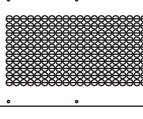
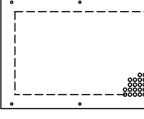
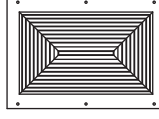
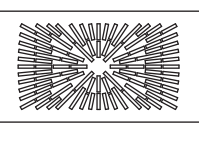
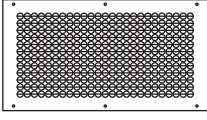
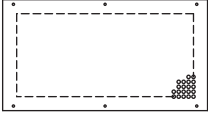
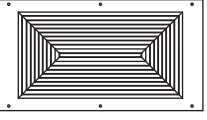
Filter size	Front plate				
<b>F10</b>	OD-9KK/AFV-8B size 310/F10 	OD-15KK/AFV-8B size 300/F10 	KD-6/AFV-8B size F10 	KD-1A/AFV-8B size 1(2)/F10 	OD-5/AFV-8B size 300/F10 
<b>F20</b>	OD-9KK/AFV-8B size F20 	OD-15KK/AFV-8B size F20 	KD-6/AFV-8B size F20 	SR-4/AFV-8B size F20 	
<b>F30</b>	OD-9KK/AFV-8B size 400/F30 	OD-15KK/AFV-8B size 400/F30 	KD-6/AFV-8B size F30 	KD-1A/AFV-8B size 2(3,4)/F30 	OD-5/AFV-8B size 400/F30 
<b>F40</b>	OD-9KK/AFV-8B size 500/F40 	OD-15KK/AFV-8B size 500/F40 	KD-6/AFV-8B size F40 	KD-1A/AFV-8B size 4(5,6)/F40 	OD-5/AFV-8B size 500/F40 
<b>F50</b>	OD-9KK/AFV-8B size 600/F50 	OD-15KK/AFV-8B size 600/F50 	KD-6/AFV-8B size F50 	KD-1A/AFV-8B size 5(6,7,8)/F50 	OD-5/AFV-8B size 600/F50 
<b>F60</b>	OD-9KK/AFV-8B size F60 	OD-15KK/AFV-8B size F60 	KD-6/AFV-8B size F60 	SR-4/AFV-8B size F60 	
<b>F70</b>	OD-9KK/AFV-8B size F70 	OD-15KK/AFV-8B size F70 	KD-6/AFV-8B size F70 	SR-4/AFV-8B size F70 	

**Table 3: Front plate weight table**

Front plate	Filter size						
	F10	F20	F30	F40	F50	F60	F70
<b>OD-5</b>	1.5 kg	/	2.7 kg	3.4 kg	4.2 kg	/	/
<b>OD-9KK</b>	1.5 kg	2.4 kg	2.6 kg	3.3 kg	4.0 kg	5.7 kg	7.3 kg
<b>OD-15KK</b>	1.3 kg	2.1 kg	2.3 kg	3.0 kg	3.7 kg	4.8 kg	6.2 kg
<b>KD-6</b>	1.0 kg	1.7 kg	1.8 kg	2.4 kg	2.9 kg	4.2 kg	5.4 kg
<b>KD-1A</b>	size 1 / 2.0 kg size 2 / 2.1 kg	/	size 2 / 3.3 kg size 3 / 3.5 kg size 4 / 3.7 kg	size 4 / 4.4 kg size 5 / 4.7 kg size 6 / 5.0 kg	size 5 / 5.5 kg size 6 / 5.8 kg size 7 / 6.4 kg size 8 / 6.5 kg	/	/
<b>SR-4</b>	/	3.7 kg	/	/	/	9.8 kg	13.0 kg

## Ordering key

**AFV-8B / F\_ / R\_ -S / O / Z / PO / OD-5**

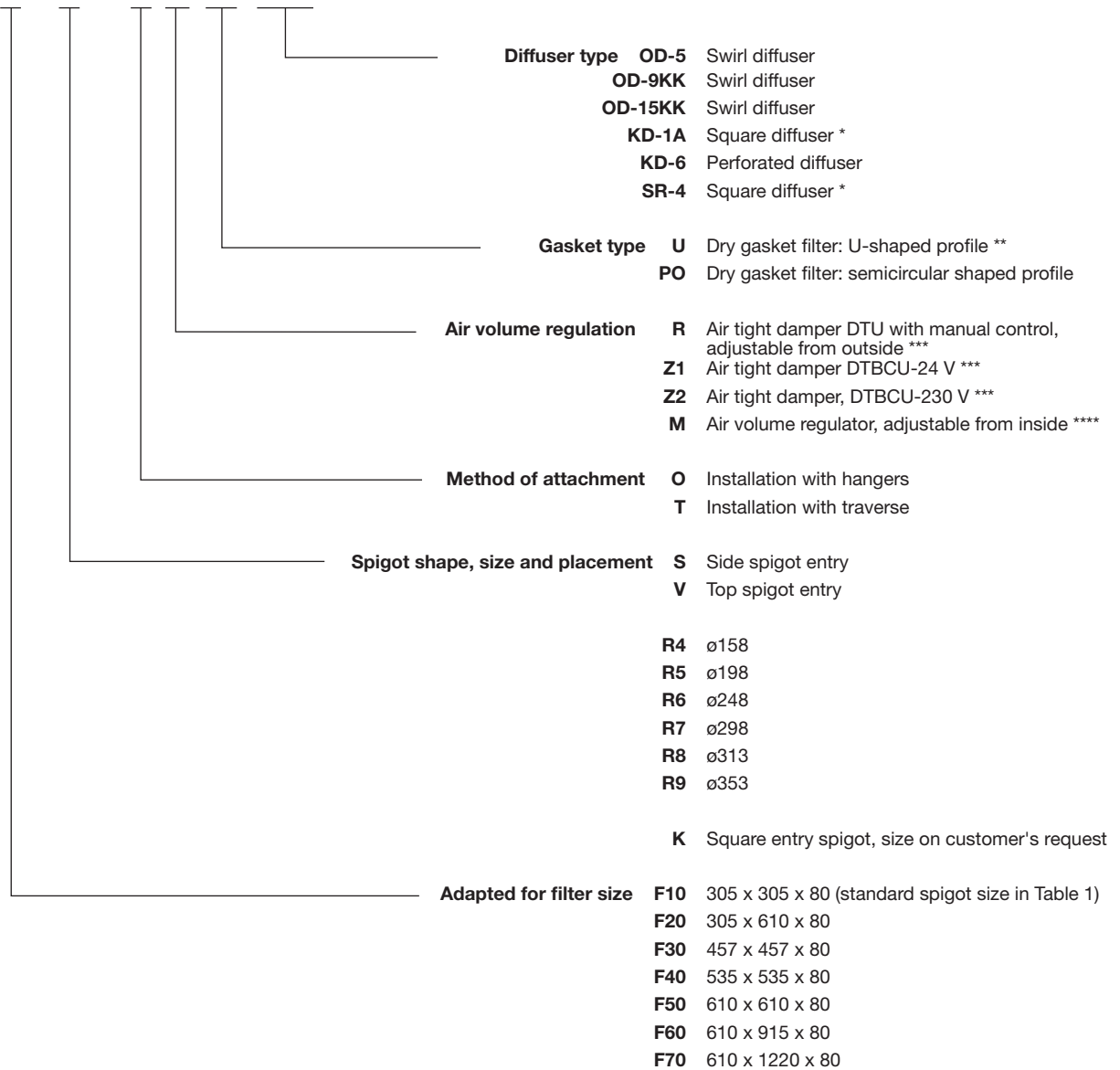

**Note:**

**Filter is not included and must be ordered separately.**

\* SR-4 is available for sizes F20, F60, F70.

\* KD-1A is available for sizes F10, F30, F40, F50.

\*\* Connection for filter sit tightness test according to DIN 1946-4.

\*\*\* Air tight damper DTBCU is possible only with version RS and RV.

\*\*\*\* Air volume regulation is possible only with version RS and spigot size R4, R5, R6.



# Ceiling HEPA filter units with gel gasket AFV-8G

## Application

Ceiling HEPA filter unit with gel gasket AFV-8G are installed in ventilating and air conditioning systems in rooms which require absolutely clean air. They can be used for both, air supply and extract applications.

## Applications

- Air supply and extract in laboratories,
- Air supply and extract in operating theatres, infection- and sterile departments,
- Air supply in electronics, precision mechanics, chemistry, pharmaceuticals and food industry,
- Air supply in film and audio tape industry,
- Air supply and extract in nuclear technology etc.

## Description

Ceiling HEPA filter unit with gel gasket AFV-8G is made filter housing, standard diffusers KD-1A, KD-6, OD-8KR, OD-9KK or OD-15KK and HEPA filter. Housing of sheet steel is air tight welded according to DIN 1946. Diffusers are made of sheet steel and powder painted with epoxy paint in white (RAL 9010). AFV-8G housing has a special sealing frame designed to fit "gasket" filters.

## Advantage of gel gasket:

With liquid sealant force, necessary to hold the filter is smaller, compared with neoprene washers, permitting lighter and cheaper housing and faster filter replacement.

## Installation

AFV-8G unit is constructed to fit into suspended ceilings.

## Types

The following ceiling HEPA filter units with gel gasket are possible:

- With circular side entry spigot (AFV-8G/RS) (fig. 2, table 1),
- With circular top entry spigot (AFV-8G/RV) (fig. 3, table 2),
- With rectangular side entry spigot (AFV-8G/KS) (fig. 4, table 3).

## Accessories

See chapter Accessories.

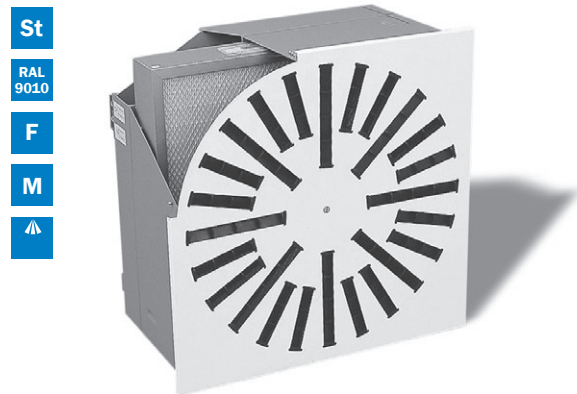
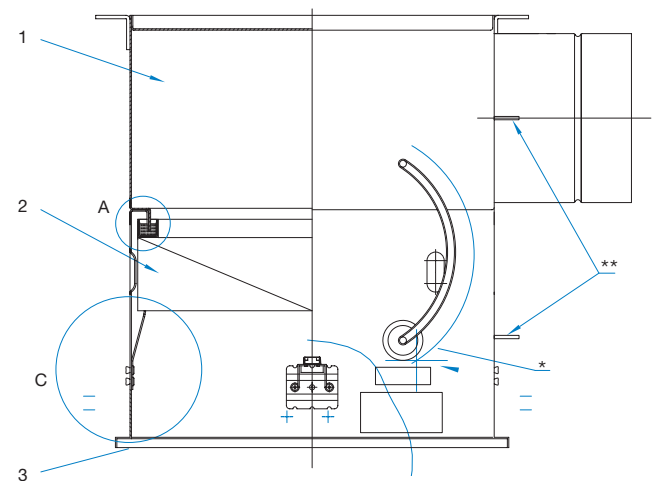
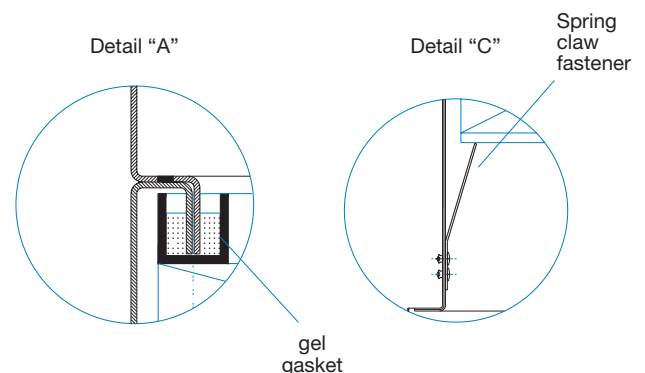

Fig. 1: Overview



- \* PAO (before: DOP) connection on the housing top section
- \*\* Pressure drop test

1. Housing
2. HEPA filter (with gel gasket)
3. Diffuser



### AFV-8G/RS circular side entry spigot

Fig. 2

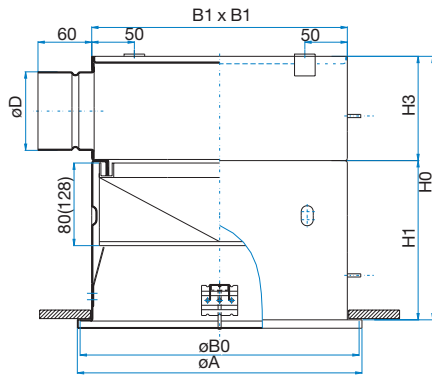

Table 1: Dimensions of AFV-8G/RS

HEPA filter unit size	HEPA filter	φD	A	B0	B1	H0	H1	H3
1	305 x 305 x 80	158	355	348	319	395	200	195
2	457 x 457 x 80	198	507	500	471	435	200	235
3A	610 x 610 x 80	198	660	653	624	435	200	235
3B	610 x 610 x 128	248	660	653	624	535	250	285
3C	305 x 610 x 80	198	355 x 660	348 x 653	319 x 624	435	200	235
4	610 x 915 x 80	313	660 x 965	653 x 958	624 x 929	550	200	350
5	610 x 1220 x 80	353	660 x 1270	653 x 1263	624 x 1234	590	200	390
6	545 x 545 x 80	198	595	588	559	435	200	235

For the data øD, H0, H3 for version with DTU or DTBCU add 5 mm to the basic version.

### AFV-8G/RV circular top entry spigot

Fig. 3

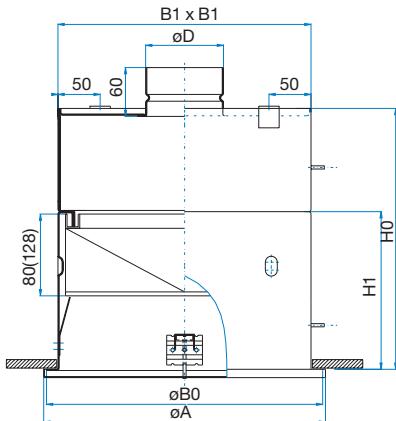
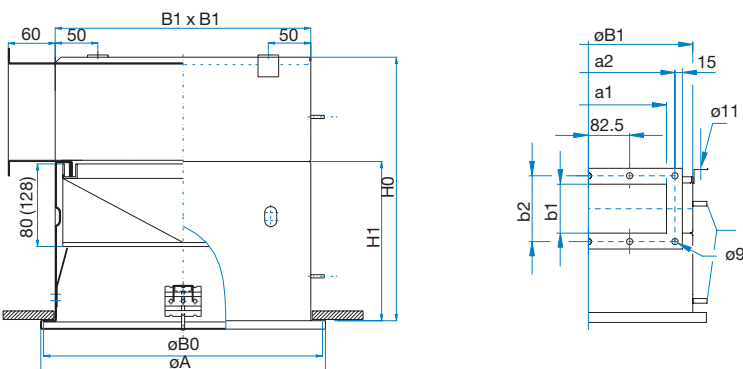

Table 2: Dimensions of AFV-8G/RV

HEPA filter unit size	HEPA filter	øD	A	B0	B1	H0	H1
1	305 x 305 x 80	158	355	348	319	280	200
2	457 x 457 x 80	198	507	500	471	280	200
3A	610 x 610 x 80	198	660	653	624	280	200
3B	610 x 610 x 128	248	660	653	624	330	250
3C	305 x 610 x 80	198	355 x 660	348 x 653	319 x 624	280	200
4	610 x 915 x 80	313	660 x 965	653 x 958	624 x 929	280	200
5	610 x 1220 x 80	353	660 x 1270	653 x 1263	624 x 1234	280	200
6	545 x 545 x 80	198	595	588	559	280	200

### AFV-8G/KS rectangular side entry spigot

Fig. 4



**Table 3:** Dimensions of AFV-8G/KS

HEPA filter unit size	HEPA filter	øD	A	B0	B1	H0	H1	a1	b1	a2	b2
1	305 x 305 x 80	158	355	348	319	314	200	250	100	285	135
2	457 x 457 x 80	198	507	500	471	314	200	400	100	435	135
3A	610 x 610 x 80	198	660	653	624	314	200	500	100	535	135
3B	610 x 610 x 128	248	660	653	624	414	250	500	150	535	185
3C	305 x 610 x 80	198	355 x 660	348 x 653	319 x 624	314	200	500	100	535	135
4	610 x 915 x 80	313	660 x 965	653 x 958	624 x 929	314	200	800	100	835	135
5	610 x 1220 x 80	353	660 x 1270	653 x 1263	624 x 1234	314	200	1000	100	1035	135
6	545 x 545 x 80	198	595	588	559	314	200	400	100	435	135

### Diffuser types

- Sheet steel painted in RAL
- Stainless sheet steel (except KD-1)
- Standard deflector colours are black

### Technical data

Possible combinations of diffuser size regarding the size of filter unit and HEPA filter is specified in table 4. Mounting dimensions of diffusers to be installed in v AFV-8G are specified in tables 1, 2, 3 and in column A.

KD-1A



KD-6

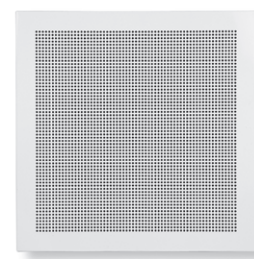

OD-8KR

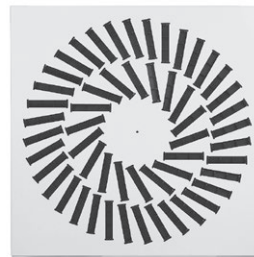

OD-9KK

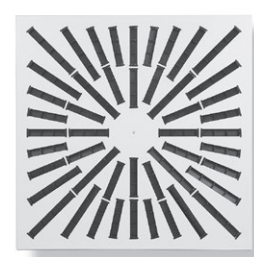

OD-15KK

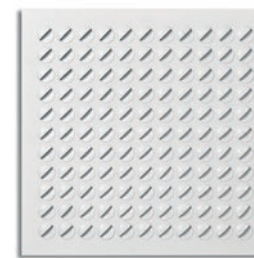

### Technical data for HEPA filters

Size and flow characteristics of HEPA filters installed in AFV-8G are specified chapter Filter.

In case filters operate under the air flow volume larger or smaller then nominal air flow, pressure drop is being increased or decreased.

### Definition of symbols

$A_{ef}$  (m<sup>2</sup>) Effective area

**Table 4:** Combinations of HEPA filter units with different front plate shapes

HEPA filter unit size	HEPA filter	A*	KD-6	OD-8KR	OD-9KK	OD-15KK
1	305 x 305 x 80	355 x 355	√	-	√	√
2	457 x 457 x 80	507 x 507	√	√	√	√
3A	610 x 610 x 80	660 x 660	√	√	√	√
3B	610 x 610 x 128	660 x 660	√	√	√	√
3C	305 x 610 x 80	660 x 355	√	-	√	√
4	610 x 915 x 80	660 x 965	√	-	√	√
5	610 x 1220 x 80	660 x 1270	√	-	√	√
6	545 x 545 x 80	595 x 595	√	√	√	√

\* Outer dimension of diffuser front plate.

**Table 5:** Effective discharge area A<sub>ef</sub>

Filter unit size	KD-6	OD-8KR A <sub>ef</sub> (m <sup>2</sup> )	OD-9KK	KD-1A	A <sub>ef</sub> (m <sup>2</sup> )
1	0.0342	-	0.0189	1	0.0104
2	0.0743	0.0300	0.0414	2	0.0185
3A	0.1368	0.0450	0.0651	3	0.0279
3B	0.1368	0.0639	0.0651	4	0.0440
3C	0.0684	-	0.0288	5	0.0628
4	0.1980	-	0.1088	6	0.0728
5	0.2664	-	0.1348	7	0.1175
6	0.1095	0.0450	0.0509	8	0.1280

### Filter and front plate combinations

#### Front plate OD-8KR

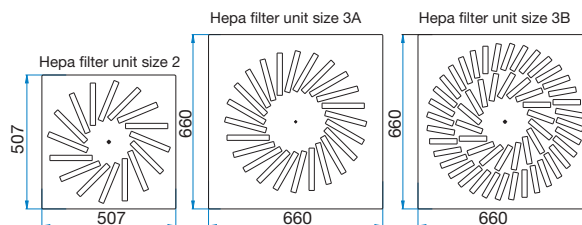

#### Front plate OD-9KK

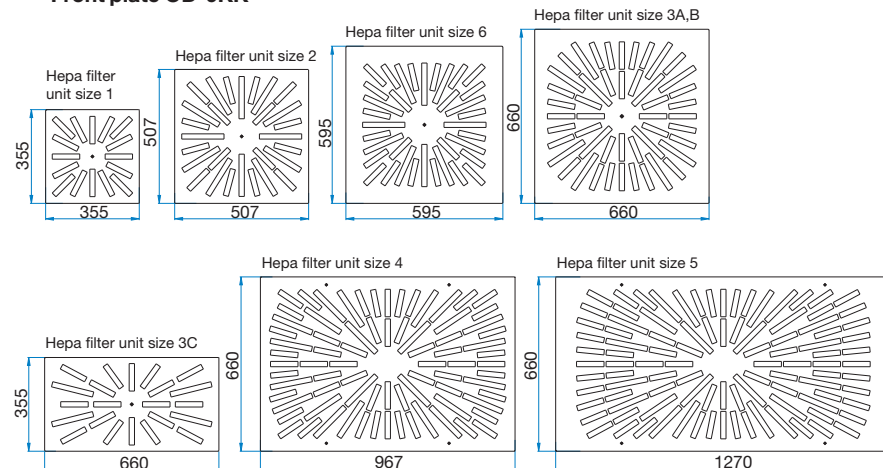

## AFV-8G with airtight damper DTU

### Application

On the Ceiling HEPA filter units with gel gasket AFV-8G a shut-off damper DTU is installed in the housing connection. The shut-off damper DTU conforms to the EN 1751 class 4 standard requirements.

The advantage of such a combination of an HEPA filter housing and a shut-off damper is the ability to close the shut-off damper during the filter exchange and thereby to prevent room air pollution. Upon the completion of the filter exchange, the shut-off damper is reopened. Such a filter exchange procedure eliminates the need to disinfect the room, which is mandatory in the case of exchanging the filter without shutting-off the inlet of non-filtered air.

### Description

On the connection of the standard AFV-8G unit, a galvanised sheet steel shut-off damper is mounted by means of four screws. The damper may be controlled either manually or by means of an electric motor.

### Expected service life of HEPA filter and replacement

HEPA filter are constructed for single use only. Expected service life of filter depends on air flow volume, pressure drop and amount of dust particles. When air flow volume is reduced for 25 %, expected service life of HEPA filter doubles. Service life can be considerably increased with installation of pre-filter. The dirtiness of the filter is controlled by the means of differential manometer. Connections for plastic tubes are fitted on AFV-8G housings.

The initial pressure drop is specified in Filter chapter. When the pressure drop has reached double its initial value, it is recommended to replace the HEPA filter. When replacing the AFV-8G filter, remove diffuser and press the springs to unlock filter and finally remove the filter (fig. 1, detail C). When installing the new filter press the filter frame until mounting springs lock at the bottom of the filter frame.

### Ordering key

#### AFV-8G / RS1 / R / KD-6 / RAL

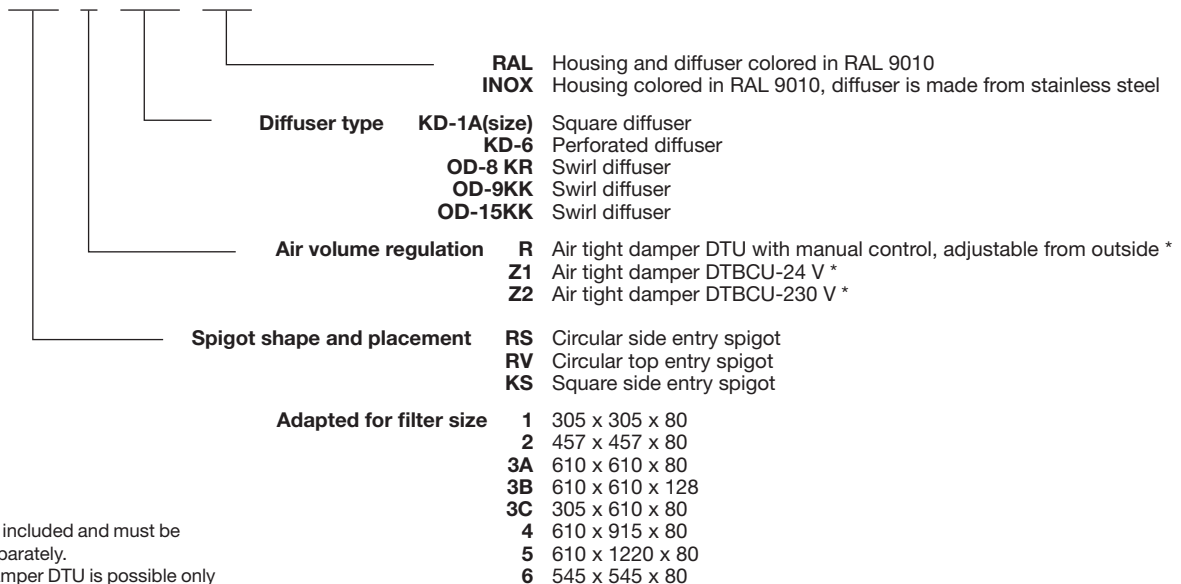

**Note:**

Filter is not included and must be ordered separately.

\* Air tight damper DTU is possible only with version RS and RV.

Fig. 6

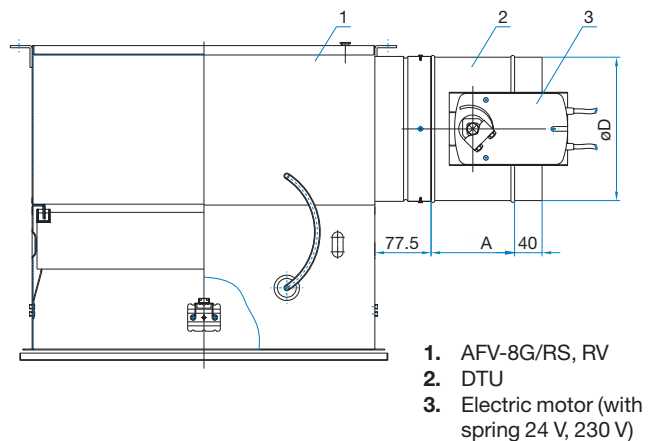

Table 6: Dimensions of AFV-8G with shut-off damper DTU

HEPA filter unit size	HEPA filter	Size DTU	
		øD	A
1	305 x 305 x 80	158	100
2	457 x 457 x 80	198	130
3A	610 x 610 x 80	198	130
3B	610 x 610 x 128	248	130
3C	305 x 610 x 80	198	130
4	610 x 915 x 80	313	130
5	610 x 1220 x 80	353	130
6	545 x 545 x 80	198	130

# Operating theatre ceiling – perforated version DPS, DPS-N

## Application

DPS with absolute filter is being used in clean rooms which require clean air but also laminar air flow within the working area. They are designed to be built into the suspended ceilings of OP rooms and intensive care premises and to ensure a laminar flow of clean air into the target zone. The aim of the above device is to reduce the possibility of infection in OP rooms being caused by germs which are due to different causes constantly present in the premises and surroundings. DPS is suitable for OP rooms class Ib by DIN 1946-4.

## Description

The preparation of air for the OP theatre is accomplished with separate air conditioning system, capable of rough and fine air-filtering according to DIN 24185. The filtered supply air is distributed to the absolute filter on the DPS plenum box. The air is discharged from the pressure chamber into the OP theatre via the perforated ceiling plates. The temperature of the discharged air is to be 1° to 3 °C lower than the average room temperature. Two thirds of the air current should be led out of the room via the floor and one third via the ceiling. The air current which is being discharged from the DPS flows over the entire area under the ceiling thus preventing the surrounding air from penetrating within the operation area (fig. 1).

## Base material of pressure chambers and perforated plates

Steel sheet painted with epoxy powder paint RAL 9010, resistant to disinfectants.

Some ceilings are composed of two parts, which are bolt together at the assembly point. In the assembly operations the connections are additionally packed with the acrylic putty, which is attached to the ceiling.

At the consumer's request the ceiling contains a transition for the operating light of the dimensions 300 x 300 mm. In that case a blind plate and a plate with a round opening of  $\varnothing 150$  mm.

Perforated plates (from inside the ceiling) are covered with white Coarse 60% filter for a more uniform distribution of air. The delivered foam is packed in a foil in order to protect it from dirt and damage.

Fixation of the perforated plates is on the one hand carried out with the help of hinges and on the other hand with the help of locks.

The ceiling is fitted with the HEPA filters 610 x 305 x 292, which belong to the class H13 or H14 and have been tested according to the EN1822:2010. They are fitted into the side connection on the longer side of the ceiling. The dimensions of the connection duct and the number of filters are given in the table. The inside of the ceiling is fitted with the filter pressure drop measurement connections (the difference between the pressure in front of and behind the filter, which serves to

- St
- RAL 9010
- F EU...
- INOX
- ▲



DPS - With transition for the light and three filters

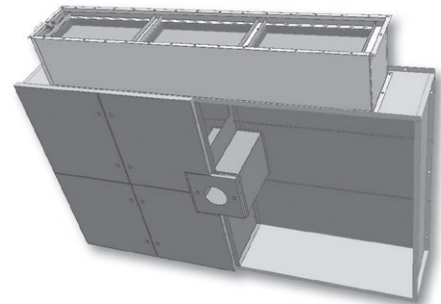

DPS - Without the transition for the light and two filters

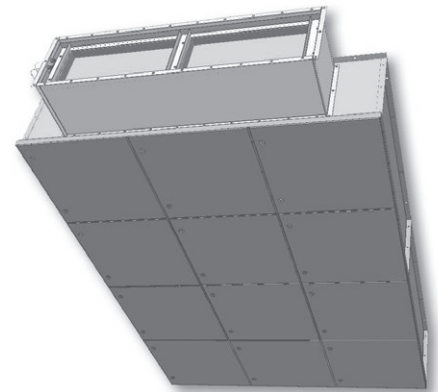
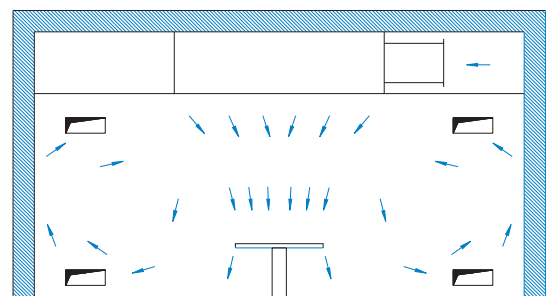

Fig. 1: DPS air flow pattern





control the dirtiness of the filter) and with the SCAN test connection.

The initial pressure drop is given in Filter chapter. At a filter load with larger or smaller flow rates than the nominal the pressure drop increases and decreases respectively, which is shown in the diagram. Leak-tightness of HEPA filter at the sealing frame is in accordance with the DIN 1946 standard, Chapter 4. When changing filters one has to check the leak-tightness of the hinges.

The ceiling, filter body, filters, white Coarse 60% filter and the assembly material are delivered separately.

The assembly of ceilings to the concrete ceiling is carried out with the threaded bars and inners for the concrete.

### HEPA filter replacement

During the operation the permeability of the HEPA filter is decreased and the differential pressure increases. The permeability-loss rate is measured with differential manometer via the tubes fitted in front and after the filter. When the pressure drop has reached double its initial value, it is recommended to replace the HEPA filter. When replacing absolute filters, the first row of face plates has to be removed.

### Accessories

See chapter Accessories.

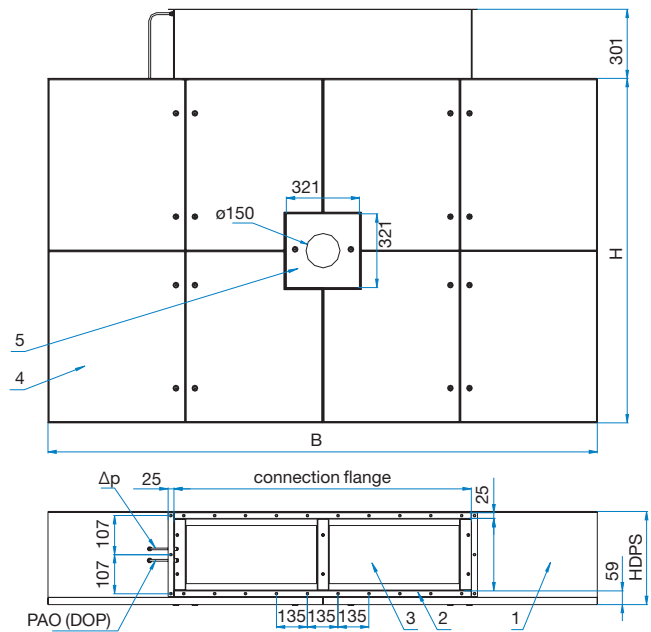

#### DPS

1. Plenum box
2. Filter housing with connection flanges
3. Filter with semicircular gasket
4. Perforated plate
5. Transition for the connection of lights

Table 1: DPS ceiling dimensions

B	H	H <sub>DPS</sub>	Q [m³/h]	Weight [kg]	No. of filters [/]	Connection lange
2000	1000	415	1700	90	2	1302 x 315
2400	1200	415	2300	122	2	1302 x 315
2400	1400	435	2700	135	3	1915 x 315
2400	1500	435	2800	149	3	1915 x 315
2400	1800	435	3300	174	4	two connections 1302 x 315
3000	1800	435	4200	210	4	two connections 1302 x 316
3000	2400	435	5800	251	6	two connections 1915 x 315
3000	3000	435	7200	320	8	four connections 1302 x 315

### Operating ceiling DPS-N

Version DPS-N has filters mounted behind mask (not in the connection ducts, as DPS).

### DPS-N Material, surface protection and assembly

- The housing of DPS-N operating ceilings is made from cold rolled steel, powder painted in RAL 9010, resistant to disinfectants or in INOX version (stainless steel AISI 304).
- On customer's request the ceiling contains a transition for the operating light. In that case a blind plate and a plate with a round opening of 150 mm.
- Fixation of the perforated plates is carried out with hinges on one side and with locks on the other side.
- The ceiling type DPS-N is fitted with HEPA filters which are inserted above the perforated mask over the entire



surface. The dimensions of the connection spigot and weights are given in Table 2.

- The inside of the ceiling is fitted with filter pressure drop measurement connections (the difference between the pressure before and behind the filter, which serves to control the dirtiness of the filter) and with the SCAN test connection.
- The mounting of ceilings to the concrete ceiling is carried out with threaded bars and inners for the concrete.
- Pressure chambers are made of two or three parts, which are screwed together at the installation site. In the assembly operations the connections are additionally packed with the acrylic putty, which is attached to the ceiling.

Fig. 2 DPS-N operating ceiling

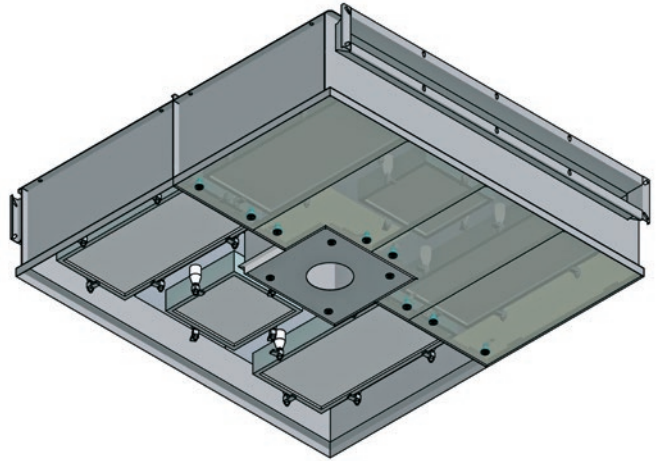
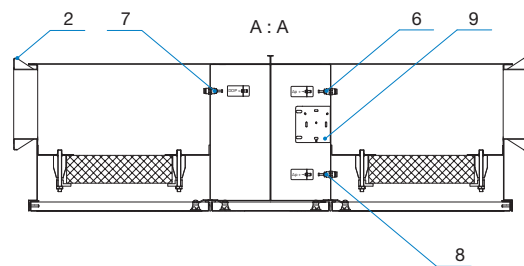
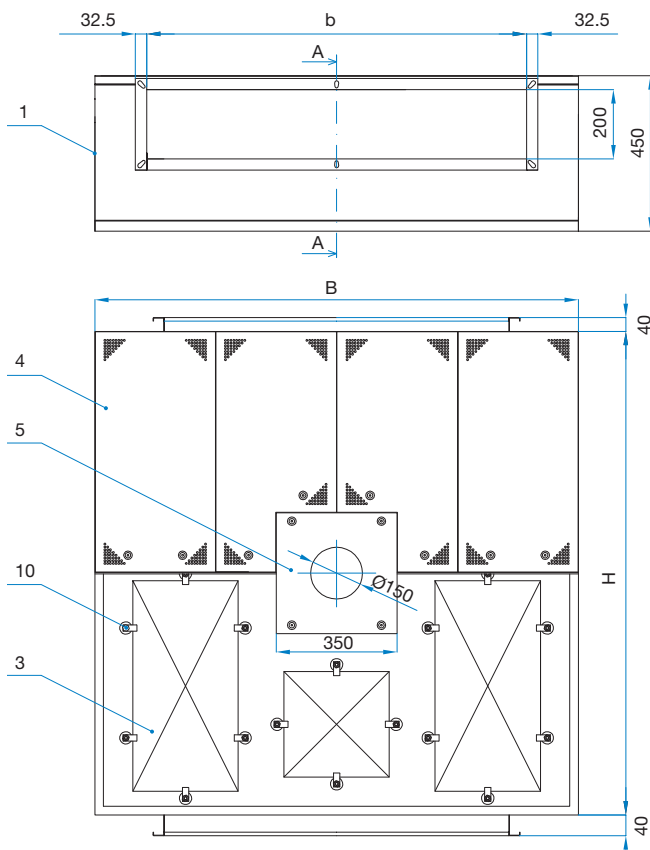

Table 2: DPS-N ceiling dimensions

B	H	H <sub>DPS</sub>	Q [m3/h]	Weight [kg]	Connection flange
2000	1000	450	1200	110	200 x 800
2400	1200	450	2400	150	200 x 1200
2400	1400	450	2700	165	200 x 1300
2400	1500	450	3080	180	two connections 200 x 750
2400	1800	450	3300	230	two connections 200 x 800
3000	1800	450	4500	275	two connections 200 x 1100
3000	2400	450	6000	325	two connections 200 x 1500
3000	3000	450	9000	405	two connections 200 x 2200
3200	3200	450	10800	490	two connections 200 x 2600

DPS-N - B x H / L / S



Legend

1. Pressure chamber
2. Filter housing
3. HEPA filter
4. Perforated mask
5. Blend plate with or without opening
6. Static pressure connection before filter + Δp
7. Connection (UPSTREAM) for scan test
8. Static pressure connection after filter - Δp
9. Holder for pressure gauge
10. Filter holder

**DPS-N** - positions of spigots and HEPA filte

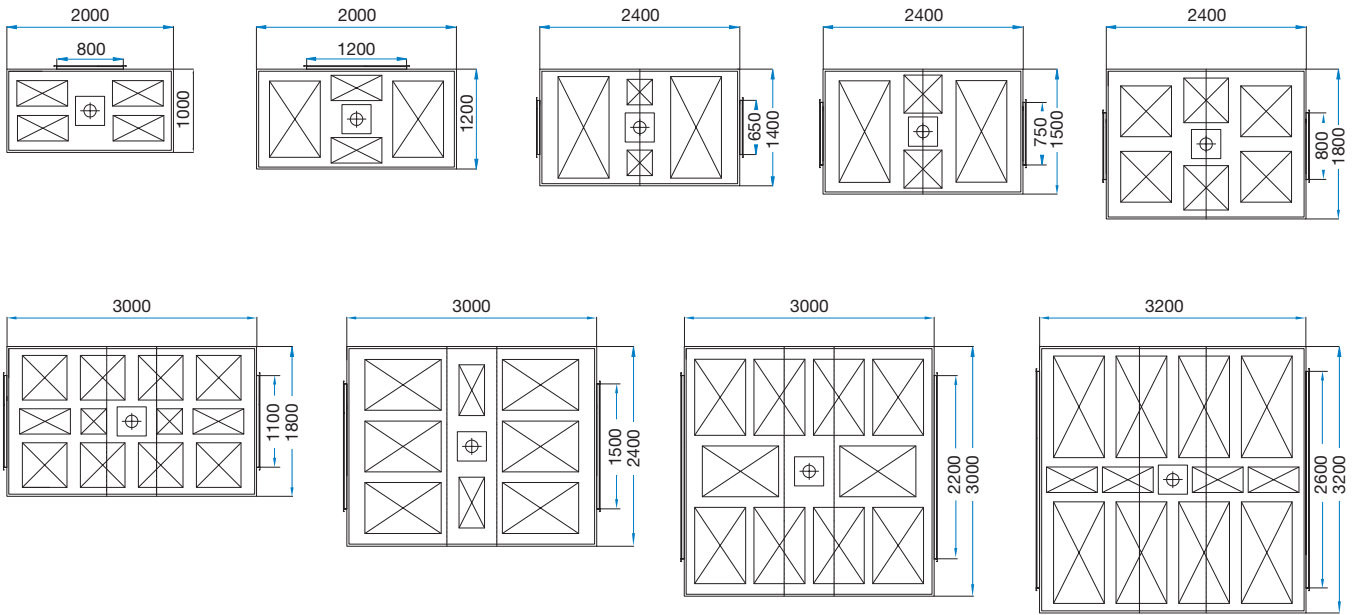

**Ordering key**

**DPS – B x H / L / S / H13 / RAL**

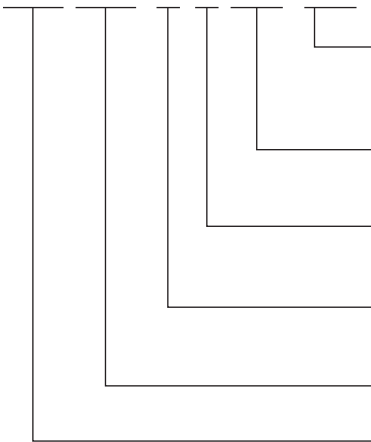

- RAL** Colored cold rolled steel  
(standard color RAL 9010)
- INOX** Stainless steel
- H13**  $\geq 99,95$  % filter classification EN 1822:2010
- H14**  $\geq 99,995$  %
- S** Side spigot entry
- V** Vertical spigot entry (on customers request)
- L** Opening for lamp  
- without opening for lamp
- BxH** DPS dimension (see Table 1)
- DPS** Filters in spigot
- DPS-N** Filters in mask

**Note:**

Filters are included in DPS housing  
It is possible, in case of special demand, to produce DPS in special sizes and for optional air flow volume.

# Operating theatre ceiling – textile version DSS, DSS-N

DSS ventilation ceiling with polyester textile is used to air condition hospitals where intensive air exchange is required. It is intended to be built into a suspended ceiling in operating rooms and intensive care facilities. DSS is suitable for OP rooms class Ib by DIN 1946-4.

## Description

The basis of the ceiling is a standard DPS perforated ventilation ceiling whose panels are replaced with synthetic textile affixed to stainless steel frames. The ceiling and filter housing may be either stainless steel or epoxy painted sheet steel.

The synthetic textile allows laminar flow, because the tight weave of the fibers prevents turbulent flow from forming on the surface. The polyester textile adheres to DIN 4799 standards for the hygienic minimum for operating rooms. It has also all the necessary certificates for use in operating rooms, and it has high resistance to aggressive disinfectants. The synthetic textile may be single-layer or double-layer. The second layer allows the air to be evenly distributed across the entire surface before it enters the room.

Ceilings are made of one, two or four parts, depending on size. All elements are screwed together at the installation site.

The supply ceiling is also available with a transition for an operation light with dimensions of 300 x 300 mm. In this case a plate with a round opening for the lamp is attached.

Fastening of the synthetic mask is done by special screws that are fixed manually, without special tools.

- St
- RAL 9010
- F EU...
- M
- INOX

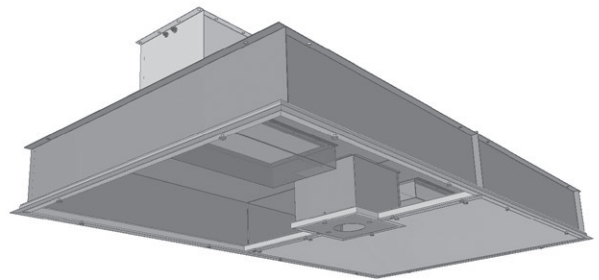

## DSS - connection from side

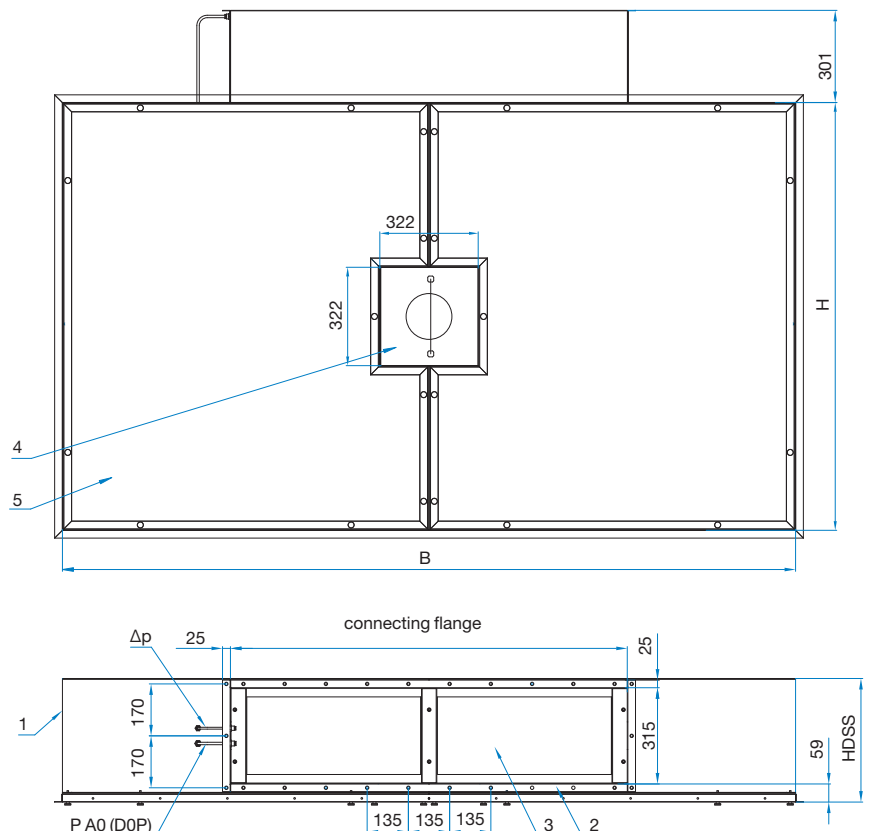

1. Pressurized plenum box
2. Filter housing with connecting flange
3. Filter
4. Transition for lamp connection
5. Mask with the cloth

They are built in the connections from the side or from the top. Dimensions of the connecting channels and the number of filters are given in the table. Connection is possible from the side or from the top, depending on the customer's requirements. Inside the ceiling, connectors are built for measuring the pressure drop on filters (the difference between the pressure before and after the filter, indicating how dirty the filter is), as well as a connection for SCAN test.

After each filter change, a scan test must be performed in accordance with standards.

### Accessories

See chapter Accessories.

### Installation

Z - installation with angle

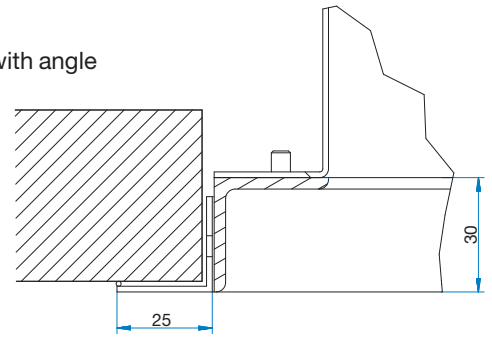

X - installation without angle

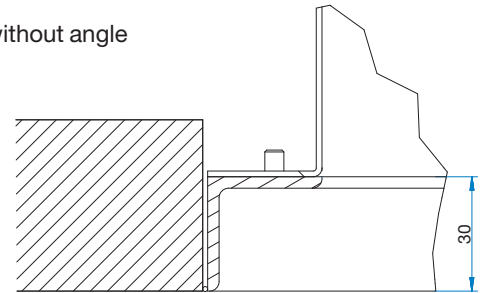

**Table 1:** DSS technical data

B	H	H <sub>DSS</sub>	Q [m³/h]	Weight [kg]	No. of filters [/]	Connection flange
2000	1000	415	1700	77	2	1302 x 315
2400	1200	415	2300	104	2	1302 x 315
2400	1400	435	2700	115	3	1915 x 315
2400	1500	435	2800	127	3	1915 x 315
2400	1800	435	3300	148	4	two connections 1302 x 315
3000	1800	435	4200	179	4	two connections 1302 x 316
3000	2400	435	5800	213	6	two connections 1915 x 315
3000	3000	435	7200	272	8	four connections 1302 x 315

At two or more connections, distance between connections is a minimum of 200 mm.

**Table 2:** DSS-N technical data

B	H	H <sub>DPS</sub>	Q [m³/h]	Weight [kg]	Connection lange
2000	1000	450	1200	110	200x800
2400	1200	450	2400	150	200x1200
2400	1400	450	2700	165	200x1300
2400	1500	450	3080	180	two connections 200x750
2400	1800	450	3300	230	two connections 200x800
3000	1800	450	4500	275	two connections 200x1100
3000	2400	450	6000	325	two connections 200x1500
3000	3000	450	9000	405	two connections 200x2200
3200	3200	450	10800	490	two connections 200x2600

**DPS-N** - positions of spigots and HEPA filters

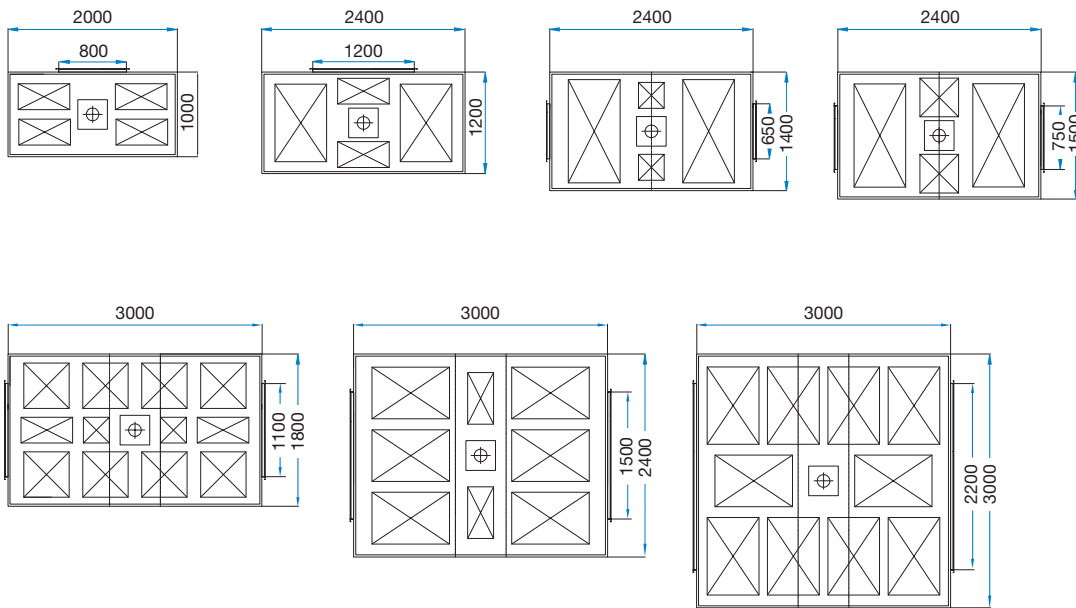

**Ordering key**

**DSS – B x H / L / S / Z / H13 / RAL**

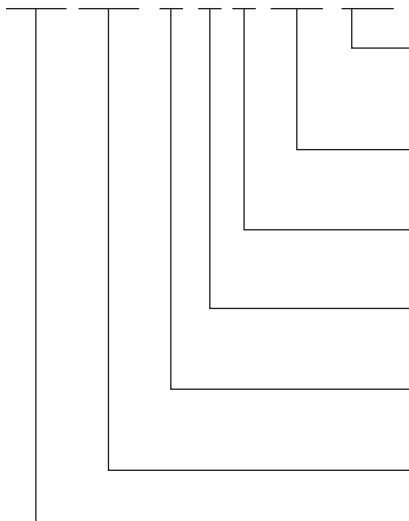

- RAL** Colored cold rolled steel (standard color RAL 9010)
- INOX** Stainless steel
- H13** ≥ 99,95 % filter classification EN 1822:2010
- H14** ≥ 99,995 %
- Z** Installation with end bracket  
- installation without end bracket
- S** Side spigot entry
- V** Vertical spigot entry (on customers request)
- L** Opening for light  
- without opening for light
- BxH** DSS dimension (see Table 1)
- DSS** Filters in spigot
- DSS-N** Filters in mask

- Note:**
- Filters are included in DSS housing.
  - It is possible, in case of special demand, to produce DSS in special sizes and for optional air flow volume.

# Fluff separator LN-1

## Application

The fluff separator is an air exhaust grille designed for wall mounting in rooms with special air purity demands (operation theatres, computer centres, ...). It is primarily used for air exhaust.

## Description

The grilles are made of stainless (grinding) sheet steel. The grille face consists of a frame with a densely woven stainless mesh welded on.

Onto the installation frame either a filter (LN-1/filter) or an air flow rate adjustment stainless steel insert F (LN-1/F) can be placed. (To adjust the insert, remove the grille face.) Front plate is fastened on the installation frame with a stainless steel screw.

## Installation

The grille may be mounted flush with the wall face.

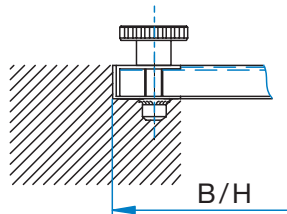

## Filter Insert Cleaning and Replacement:

Due to the build-up of impurities, the grille must be removed and cleaned. Loosen the grille face screw and simply withdraw the grille face from the installation frame. With the LN-1/ filter variant, withdraw the filter insert from the frame and replace it by a new insert.

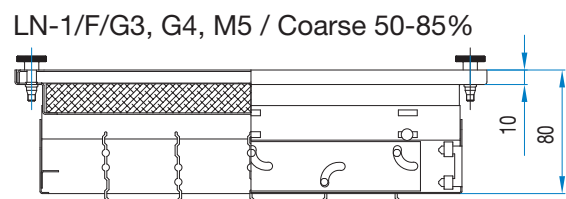
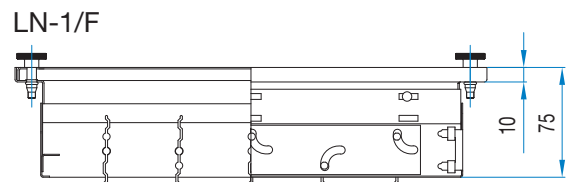
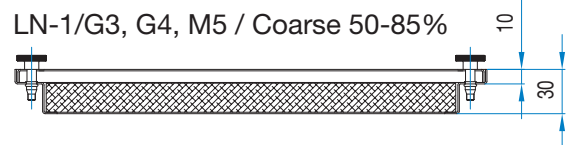
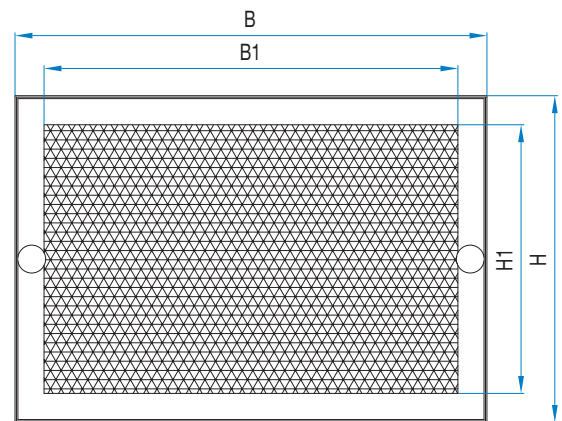
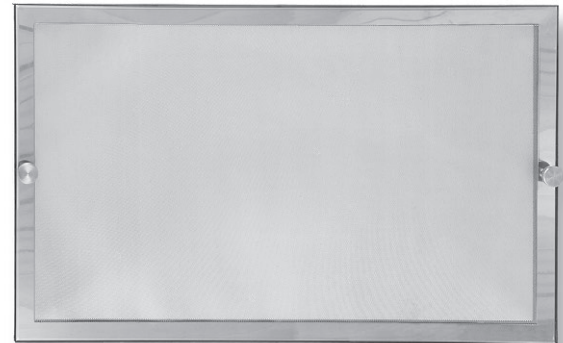

**Table 1:** Dimensions and weight

Nominal dimension		Free area		Weight [kg]			
B	H	B1	H1	LN-1	LN-1/filter	LN-1/F	LN-1/F/filter
325	225	285	185	0.7	1.2	1.5	2.0
425	225	385	185	0.9	1.4	1.9	2.4
525	225	485	185	1.0	1.7	2.2	2.9
425	325	385	285	1.0	1.7	2.3	3.0
525	325	485	285	1.1	2.0	2.7	3.6
625	325	585	285	1.3	2.3	3.1	4.1

**Note:** Deviation of weight is ±10 %.

### Ordering key

**LN-1 / M5 / F B x H**

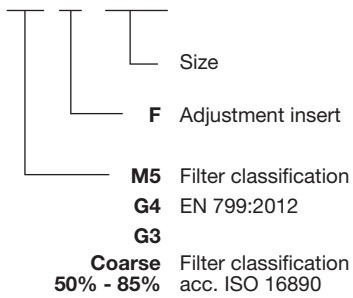

**Note:**  
Filter is not included.



# Fluff Separator LN-2

## Application

The fluff separator is an air exhaust grille designed for wall mounting in rooms with special air purity demands (operation theatres, computer centres, ...).

It is primarily used for air exhaust.

## Description

The grilles are made of stainless (grinding) sheet steel. The grille face consists of a frame with a densely woven stainless mesh welded on.

The installation frame can accommodate either a filter (LN-2/filter) or an air flow rate adjustment stainless steel insert F (LN-2/F). (To adjust the insert, remove the grille face). Front plate is fastened on the installation frame with the stainless steel screw.

## Installation

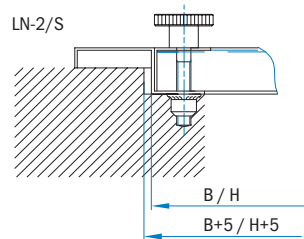

## Filter Insert Cleaning and Replacement:

Due to the build-up of impurities, the grille must be removed and cleaned. Loosen the grille face screw and simply withdraw the grille face from the installation frame.

With the LN-2/filter variant, withdraw the filter insert from the frame and replace it by a new insert.

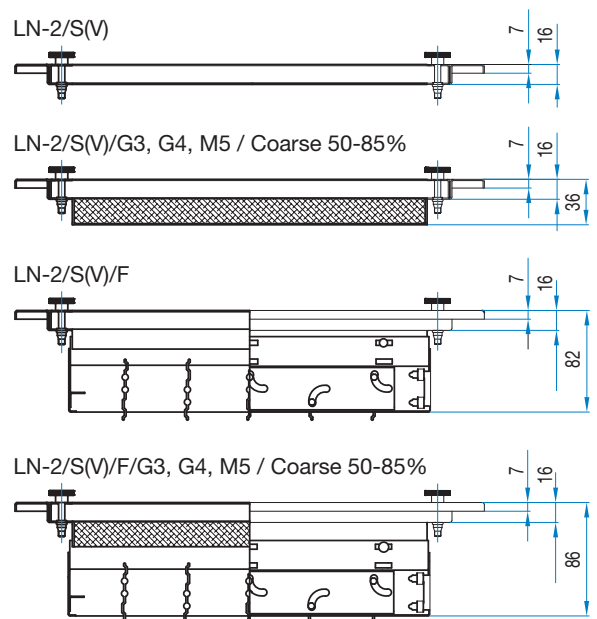
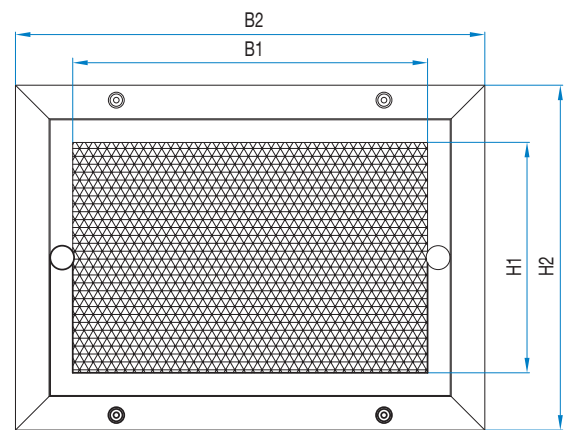

**Table 1:** Dimensions and weight

Nominal dimension		Free area		Overall dimension		Weight [kg]			
B	H	B1	H1	B2	H2	LN-2/S(V)	LN-2/S(V)/filter	LN-2/S(V)/F	LN-2/S(V)/F/filter
325	225	285	185	377	277	1.2	1.8	2.0	2.6
425	225	385	185	477	277	1.4	2.2	2.4	3.0
525	225	485	185	577	277	1.6	2.5	2.9	3.5
425	325	385	285	477	377	1.6	2.1	2.9	3.2
525	325	485	285	577	377	1.8	2.5	3.4	3.8
625	325	585	285	677	377	2.0	2.9	3.8	4.5

**Note:** Deviation of weight is ±10 %.

## Ordering key

**LN-2 / V / M5 / F B x H**

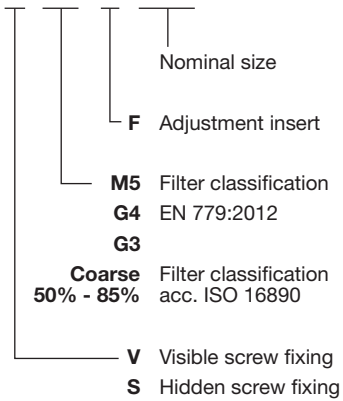

**Note:**  
Filter is not included.

# Filter grille FR

## Application

Grilles with a filter are intended to be built in the walls of rooms which require cleaner air (computer centres, libraries, clean rooms, etc.). Primarily used for exhaust air from the room.

## Description

Grilles are made of stainless (polish) sheet metal. The installed filter is of Coarse 50% - Coarse 85% filter class according to ISO 16890 (old designation: G3, G4 or M5).

## Dimensions

Standard dimensions of louvres are 225 x 225 mm to 625 x 625. The depth of the grilles is 35 mm. Other dimensions on request.

## Installation

Grilles may be fixed with visible screws (V marking, screws on the grille frame) or hidden into the installation frame (marking 2, grille is fastened to the installation frame with the lock on the internal side of the grille. Installation frame shall be fixed on the wall before the installation of the grille.)

1. by screws (designation V)

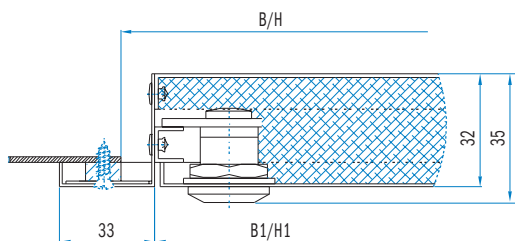

2. onto the installation frame (designation 2)

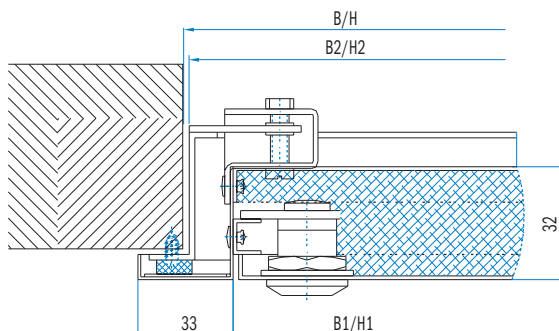

## Filter replacement

Due to the dirtiness of a filter, the pressure drop on a louvre gradually increases, therefore it is necessary to replace the filter. The replacement of a filter is quick and simple. Lock may be used to open the grille and replace dirty filter with the new one. The mask is then closed by means of a lock.

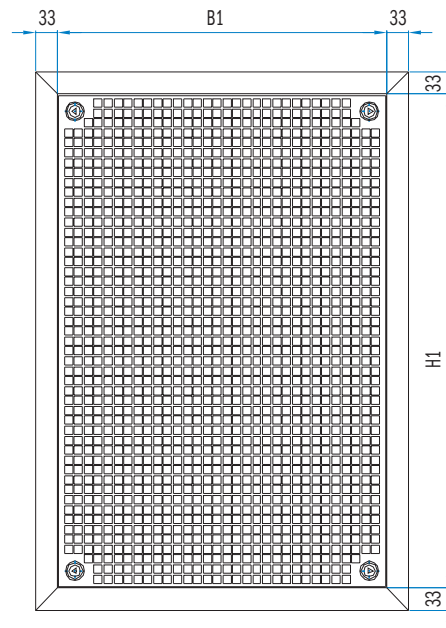
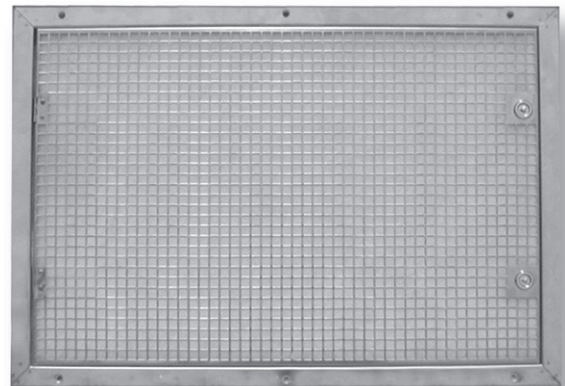

**Table 1:** Dimensions and weights

B	H	B1	B2	H1	H2	Weight [kg]	
						FR/2	FR/V
225	225	198	222	198	222	1.4	0.8
325		298	322			1.8	1.1
425		398	422			2.1	1.3
525		498	522			2.5	1.6
625		598	622			2.8	1.8
325	325	298	322	298	322	2.1	1.4
425		398	422			2.6	1.8
525		498	522			3.1	2.1
625		598	622			3.5	2.5
425	425	398	422	398	422	3.1	2.2
525		498	522			3.6	2.6
625		598	622			4.2	3.0
525	525	498	522	498	522	4.2	3.2
625		598	622			4.9	3.6
625	625	598	622	598	622	5.6	4.2

**Note:** Deviation of weight is ±10 %.

### Ordering key

**FR / V / M5 / F B x H**

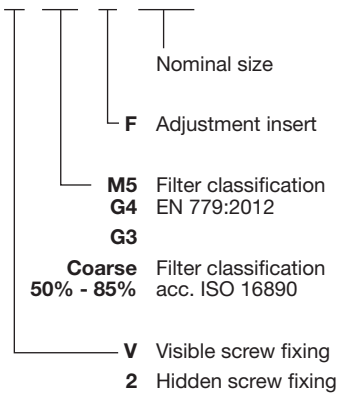

# Filters

**Table 1:** Quick selection table according to filter class

Filter group	Filter class EN 779:2012	Filter class ISO 16890	Average arrestance (Am) of synthetic dust	Average efficiency (Em) of 0,4 µm particles	Minimum efficiency of 0,4 µm particles	Filter type
Coarse	G1	Coarse 50%	$50 \% \leq A_m < 65 \%$	–	–	Bag filters (FV) Panel filters (KA) Roll filters (FR)
	G2	Coarse 50%	$65 \% \leq A_m < 80 \%$	–	–	
	G3	Coarse 50-55%	$80 \% \leq A_m < 90 \%$	–	–	
	G4	Coarse 60-65%	$90 \% \leq A_m$	–	–	
Medium	M5	Coarse 85-90%	–	$40 \% \leq E_m < 60 \%$	–	Bag filters (FV) Panel filters (KA) Compact filters (KO)
	M6	ePM10 65%	–	$60 \% \leq E_m < 80 \%$	–	
Fine	F7	ePM2,5 65%	–	$80 \% \leq E_m < 90 \%$	35	
	F8	ePM1 75%	–	$90 \% \leq E_m < 95 \%$	55	
	F9	ePM1 80%	–	$95 \% \leq A_m$	70	

**Table 2:** Quick selection table according to filter class EPA, HEPA, ULPA

Filter group	Filter class	According to standard	Value Efficiency (MPPS)	Filter type
<b>E</b> ... EPA filters Efficient Particulate Air Filter	E10	EN 1822-1:2010	≥ 85 %	Compact filters (KO) EPA,HEPA,ULPA filters (H)
	E11		≥ 95 %	
	E12		≥ 99,5 %	
<b>H</b> ... HEPA filters High Efficiency Particulate Air Filter	H13		≥ 99,95 %	
	H14		≥ 99,995 %	
<b>U</b> ... ULPA filters Ultra Low Penetration Air Filter	U15		≥ 99,9995 %	
	U16		≥ 99,99995 %	
	U17		≥ 99,999995 %	

**Table 3:** Quick selection table according to application for carbon filters

Application type	Contaminants	Filter type
C1	Airports, Pharms & Food / Hydrocarbons	Carbon filters (FO)
C2	Industry / Mineral acids	
C3	Industry / Ammonia, amines	
C4	Industry & Waste water / (H <sub>a</sub> S), (SO <sub>2</sub> )	
C5	Museums & Libraries / H <sub>2</sub> S, S <sub>ox</sub> , NO <sub>x</sub> formaldehyde	
C6	General Purpose / General Gas Removal	
C7	Nuclear industry / Radioactive dust particles	

**Equation 1:** Quick calculation of fan energy consumption for one filter

$$E = \frac{q_v \times \Delta p \times t}{\eta_f \times 1000}$$

## Definition of symbols

- E [kWh]** energy consumed by fan
- q<sub>v</sub> [m<sup>3</sup>/s]** air flow rate at filter
- Δp [Pa]** filter pressure drop
- t [h]** operating time
- η<sub>F</sub> [/]** fan efficiency (usually from 0.6 – 0.8)

# EPA, HEPA, ULPA filters

## Liquid gasket, gel

- filter version: Filter ... standard
- manufacturer: American Air Filter
- frame material: aluminum
- temperature limit: 70 °C
- recommended final pressure: 500 Pa
- suitable for: AFV-8G

**Table 4:** Filter technical data H-H14/G/ALU/AAF/F\_

Nominal size	Filter dimension			Filter class	
	Width W	Depth D	Height H	Pressure drop $\Delta p_s$	Airflow Q
	[mm]	[mm]	[mm]	[Pa]	[m³/h]
F10	305	x 305	x 80	125	150
F20	305	x 610	x 80	125	300
F30	457	x 457	x 80	125	340
F50	610	x 610	x 80	125	600
F60	610	x 915	x 80	125	900
F70	610	x 1220	x 80	125	1200
F80	545	x 545	x 80	125	480
F51	610	x 610	x 128	75	600

**Picture 1:** Filter drawing H-H14/G/ALU/AAF/F\_

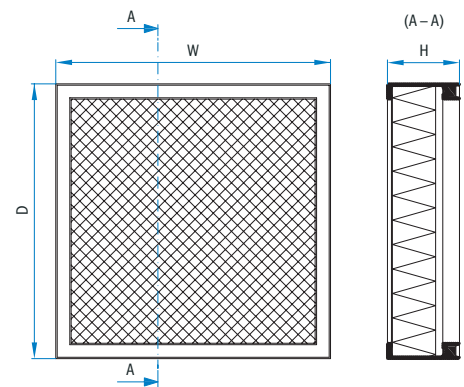

## Dry gasket, U-shaped profile

- filter version: Filter ... standard
- manufacturer: American Air Filter
- frame material: MDF wood
- temperature limit: 70 °C
- recommended final pressure: 600 Pa
- suitable for: AFV-8B

**Table 5:** Filter technical data H-H/U/MDF/AAF/F\_

Nominal size	Filter dimension			Filter class			
	Width W	Depth D	Height H	Pressure drop $\Delta p_s$	Airflow Q	Pressure drop $\Delta p_s$	Airflow Q
	[mm]	[mm]	[mm]	[Pa]	[m³/h]	[Pa]	[m³/h]
F10	305	x 305	x 78	250	250	320	250
F20	305	x 610	x 78	250	500	320	500
F30	457	x 457	x 78	250	570	320	570
F40	535	x 535	x 78	250	770	320	770
F50	610	x 610	x 78	250	1000	320	1000
F80	545	x 545	x 78	250	800	320	800

**Picture 2:** Filter H-H/U/MDF/AAF/F\_

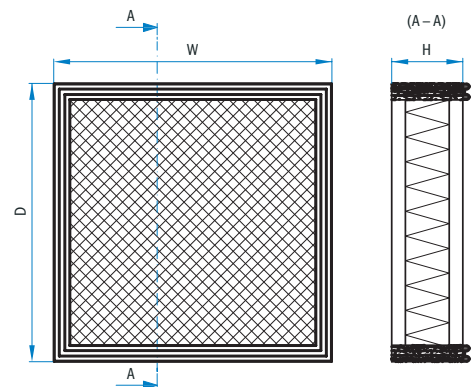

### Dry gasket, semicircular profile

- filter version: Filter ... standard
- manufacturer: Lindab
- frame material: MDF wood
- temperature limit: 70 °C
- recommended final pressure: 600 Pa
- suitable for: AFV-8B, AKF, DPS, DSS

**Table 6:** Filter technical data H-H\_/PO/MDF/LIN/F\_

Nominal size	Filter dimension			Filter class			
	Width W [mm]	Depth D [mm]	Height H [mm]	H13		H14	
				Pressure drop $\Delta p_s$ [Pa]	Airflow Q [m³/h]	Pressure drop $\Delta p_s$ [Pa]	Airflow Q [m³/h]
F10	305	x 305	x 78	250	300	120	150
F20	305	x 610	x 78	250	600	120	300
F30	457	x 457	x 78	250	680	120	340
F50	610	x 610	x 78	250	1200	120	600
F80	545	x 545	x 78	250	950	120	475
F12	305	x 305	x 150	250	300	120	150
F22	305	x 610	x 150	250	600	120	300
F32	457	x 457	x 150	250	680	120	340
F52	610	x 610	x 150	250	1200	120	600
F13	305	x 305	x 292	250	500	280	500
F23	305	x 610	x 292	250	1000	280	1000
F33	457	x 457	x 292	250	1100	280	1100
F53	610	x 610	x 292	250	2000	280	2000

**Picture 3:** Filter drawing H-H\_/PO/MDF/LIN/F\_

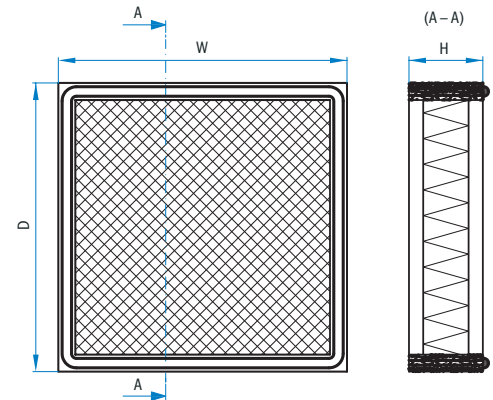

### Dry gasket, semicircular profile

- filter version: Filter ... standard
- manufacturer: American Air Filter
- frame material: MDF wood
- temperature limit: 70 °C
- recommended final pressure: 600 Pa
- suitable for: AKF

**Table 7:** Filter technical data H-H\_/PO/MDF/AAF/F\_

Nominal size	Filter dimension			Filter class			
	Width W [mm]	Depth D [mm]	Height H [mm]	H13		H14	
				Pressure drop $\Delta p_s$ [Pa]	Airflow Q [m³/h]	Pressure drop $\Delta p_s$ [Pa]	Airflow Q [m³/h]
F12	305	x 305	x 150	250	250	320	250
F22	305	x 610	x 150	250	500	320	500
F32	457	x 457	x 150	250	570	320	570
F52	610	x 610	x 150	250	1000	320	1000
F13	305	x 305	x 292	250	500	320	500
F23	305	x 610	x 292	250	1000	320	1000
F33	457	x 457	x 292	250	1130	320	1130
F53	610	x 610	x 292	250	2000	320	2000

**Picture 4:** Filter drawing H-H\_/PO/MDF/AAF/F\_

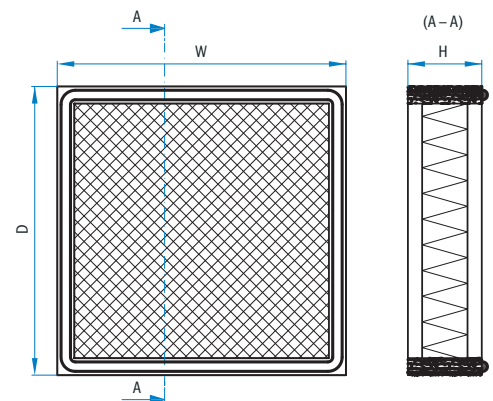



### Dry gasket, semicircular profile

- filter version: FilHF ... high flow
- manufacturer: American Air Filter
- frame material: POC galvanized steel
- temperature limit: 70 °C
- recommended final pressure: 750 Pa
- suitable for: AKF

Table 8: Filter technical data H-H\_/PO/POC/AAF/F\_

Filter dimension				Filter class			
Nominal size	Width W [mm]	Depth D [mm]	Height H [mm]	H13		H14	
				Pressure drop $\Delta p_s$ [Pa]	Airflow Q [m <sup>3</sup> /h]	Pressure drop $\Delta p_s$ [Pa]	Airflow Q [m <sup>3</sup> /h]
F23	305	x 610	x 292	250	1500	380	1500
F53	610	x 610	x 292	250	4000	380	4000

Picture 5: Filter drawing H-H\_/PO/POC/AAF/F\_

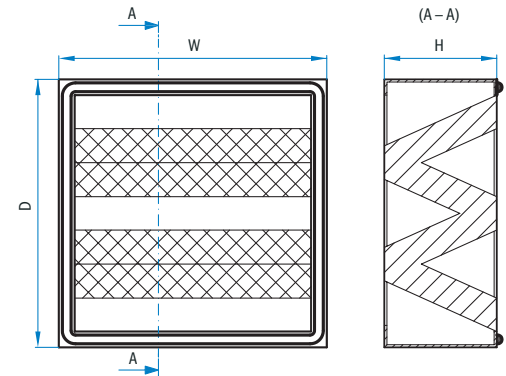

### Dry gasket, flat profile

- filter version: Filter ... standard
- manufacturer: Lindab
- frame material: MDF wood
- temperature limit: 70 °C
- recommended final pressure: 600 Pa
- suitable for: AFV-8, AFH-1

Table 9: Filter technical data H-H\_/PL/MDF/LIN/F\_

Filter dimension				Filter class			
Nominal size	Width W [mm]	Depth D [mm]	Height H [mm]	H13		H14	
				Pressure drop $\Delta p_s$ [Pa]	Airflow Q [m <sup>3</sup> /h]	Pressure drop $\Delta p_s$ [Pa]	Airflow Q [m <sup>3</sup> /h]
F10	305	x 305	x 78	250	300	120	150
F20	305	x 610	x 78	250	600	120	300
F30	457	x 457	x 78	250	680	120	340
F50	610	x 610	x 78	250	1200	120	600
F80	545	x 545	x 78	250	950	120	950
F12	305	x 305	x 150	250	300	120	150
F22	305	x 610	x 150	250	600	120	300
F32	457	x 457	x 150	250	680	120	340
F52	610	x 610	x 150	250	1200	120	600
F13	305	x 305	x 292	250	500	280	500
F23	305	x 610	x 292	250	1000	280	1000
F33	457	x 457	x 292	250	1100	280	1100
F53	610	x 610	x 292	250	2000	280	2000

Picture 6: Filter drawing H-H\_/PL/MDF/LIN/F\_

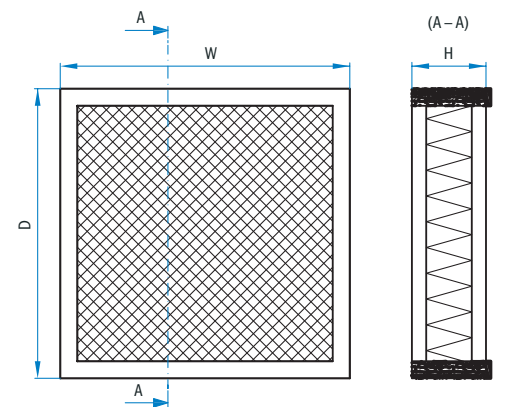

# Bag filters

## Without gasket

- filter version: Filter ... standard
- manufacturer: Lindab
- frame material: galvanized steel
- temperature limit: 80 °C
- recommended final pressure: 450 Pa (exception is 250 Pa for Coarse 50%-85%, old designation G3, G4, M5)
- suitable for: KPF

Picture 7: Filter drawing FV-G\_/-/POC/LIN/F\_

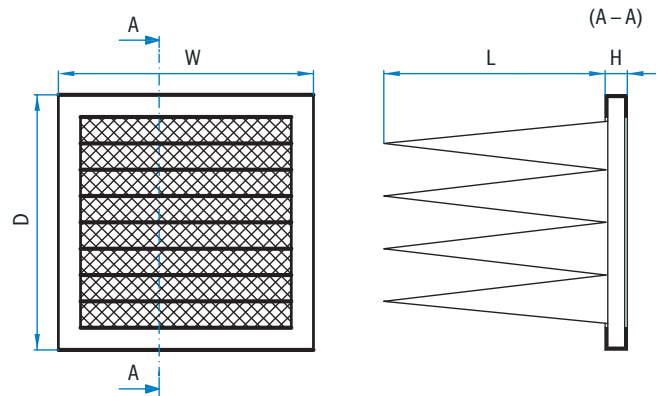

Table 10: Filter technical data FV-G\_/-/POC/LIN/F\_ ... coarse and medium filters

Filter dimension					Filter class							
					G3 / Coarse 50%		G4 / Coarse 60%		M5 / Coarse 85%		M6 / ePM10 65%	
Nominal size	Width W	Depth D	Height H	Pocket length -number L-n	Pressure drop $\Delta p_s$	Airflow Q	Pressure drop $\Delta p_s$	Airflow Q	Pressure drop $\Delta p_s$	Airflow Q	Pressure drop $\Delta p_s$	Airflow Q
	[mm]	[mm]	[mm]	[mm]	[Pa]	[m³/h]	[Pa]	[m³/h]	[Pa]	[m³/h]	[Pa]	[m³/h]
F300	287	x 287	x 25	/ 630-3	30	850	40	850	60	850	68	850
F310	287	x 490	x 25	/ 630-3	30	1400	40	1400	60	1400	68	1400
F320	287	x 592	x 25	/ 630-3	30	1700	40	1700	60	1700	68	1700
F330	490	x 490	x 25	/ 630-5	30	2400	40	2400	60	2400	68	2400
F340	490	x 592	x 25	/ 630-5	30	2800	40	2800	60	2800	68	2800
F350	592	x 592	x 25	/ 630-6	30	3400	40	3400	60	3400	68	3400

Table 11: Filter technical data FV-G\_/-/POC/LIN/F\_ ... fine filters

Filter dimension					Filter class					
					F7 / ePM2,5 65%		F8 / ePM1 75%		F9 / ePM1 80%	
Nominal size	Width W	Depth D	Height H	Pocket length -number L-n	Pressure drop $\Delta p_s$	Airflow Q	Pressure drop $\Delta p_s$	Airflow Q	Pressure drop $\Delta p_s$	Airflow Q
	[mm]	[mm]	[mm]	[mm]	[Pa]	[m³/h]	[Pa]	[m³/h]	[Pa]	[m³/h]
F300	287	x 287	x 25	/ 630-4	86	850	92	850	92	850
F310	287	x 490	x 25	/ 630-4	86	1400	92	1400	92	1400
F320	287	x 592	x 25	/ 630-4	86	1700	92	1700	92	1700
F330	490	x 490	x 25	/ 630-6	86	2400	92	2400	92	2400
F340	490	x 592	x 25	/ 630-6	86	2800	92	2800	92	2800
F350	592	x 592	x 25	/ 630-8	86	3400	92	3400	92	3400

# Panel filters

## Without gasket

- filter version: Filter ... standard
- manufacturer: Lindab
- frame material: galvanized steel
- temperature limit: 80 °C
- recommended final pressure: 450 Pa (exception is 250 Pa for filter classes Coarse 55% - 85% acc. to ISO 16890 (old designation: G3, G4, M5))
- suitable for: AKF, KPF

Picture 8: Filter drawing KA-G\_/-/POC/LIN/F\_

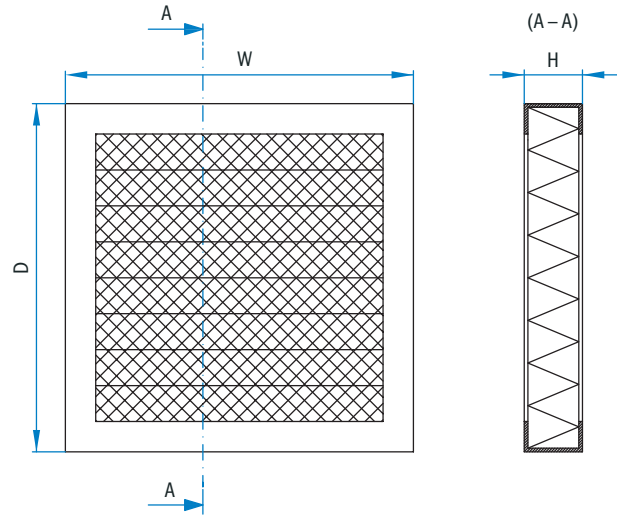

Table 12: Filter technical data KA-G\_/-/POC/LIN/F\_ ... coarse and medium filters

Filter dimension				Filter class									
Nominal size	Width W		Depth D	Height H	G3 / Coarse 50%		G4 / Coarse 60%		M5 / Coarse 85%		M6 / ePM10 65%		
	[mm]	[mm]	[mm]	[mm]	Pressure drop $\Delta p_s$ [Pa]	Airflow Q [m <sup>3</sup> /h]	Pressure drop $\Delta p_s$ [Pa]	Airflow Q [m <sup>3</sup> /h]	Pressure drop $\Delta p_s$ [Pa]	Airflow Q [m <sup>3</sup> /h]	Pressure drop $\Delta p_s$ [Pa]	Airflow Q [m <sup>3</sup> /h]	
F102	287	x	287	x	48	30	460	40	460	60	460	68	460
F112	287	x	490	x	48	30	820	40	820	60	820	68	820
F122	287	x	592	x	48	30	985	40	985	60	985	68	985
F132	490	x	490	x	48	30	1440	40	1440	60	1440	68	1440
F142	490	x	592	x	48	30	1735	40	1735	60	1735	68	1735
F152	592	x	592	x	48	30	2130	40	2130	60	2130	68	2130
F103	287	x	287	x	98	30	755	40	755	60	755	68	755
F113	287	x	490	x	98	30	1280	40	1280	60	1280	68	1280
F123	287	x	592	x	98	30	1540	40	1540	60	1540	68	1540
F133	490	x	490	x	98	30	1935	40	1935	60	1935	68	1935
F143	490	x	592	x	98	30	2325	40	2325	60	2325	68	2325
F152	592	x	592	x	98	30	2720	40	2720	60	2720	68	2720

**Table 13:** Filter technical data KA-G\_/-/POC/LIN/F\_ ... fine filters

Filter dimension				Filter class					
Nominal size	Width W [mm]	Depth D [mm]	Height H [mm]	F7 / ePM2,5 65%		F8 / ePM1 75%		F9 / ePM1 80%	
				Pressure drop $\Delta p_s$ [Pa]	Airflow Q [m³/h]	Pressure drop $\Delta p_s$ [Pa]	Airflow Q [m³/h]	Pressure drop $\Delta p_s$ [Pa]	Airflow Q [m³/h]
F102	287	x 287	x 48	83	460	86	460	86	460
F112	287	x 490	x 48	83	820	86	820	86	820
F122	287	x 592	x 48	83	985	86	985	86	985
F132	490	x 490	x 48	83	1440	86	1440	86	1440
F142	490	x 592	x 48	83	1735	86	1735	86	1735
F152	592	x 592	x 48	83	2130	86	2130	86	2130
F103	287	x 287	x 98	83	755	86	755	86	755
F113	287	x 490	x 98	83	1280	86	1280	86	1280
F123	287	x 592	x 98	83	1540	86	1540	86	1540
F133	490	x 490	x 98	83	1935	86	1935	86	1935
F143	490	x 592	x 98	83	2325	86	2325	86	2325
F152	592	x 592	x 98	83	2720	86	2720	86	2720

### Ordering key

#### Filter H-H13 / PO / MDF / AAF / size

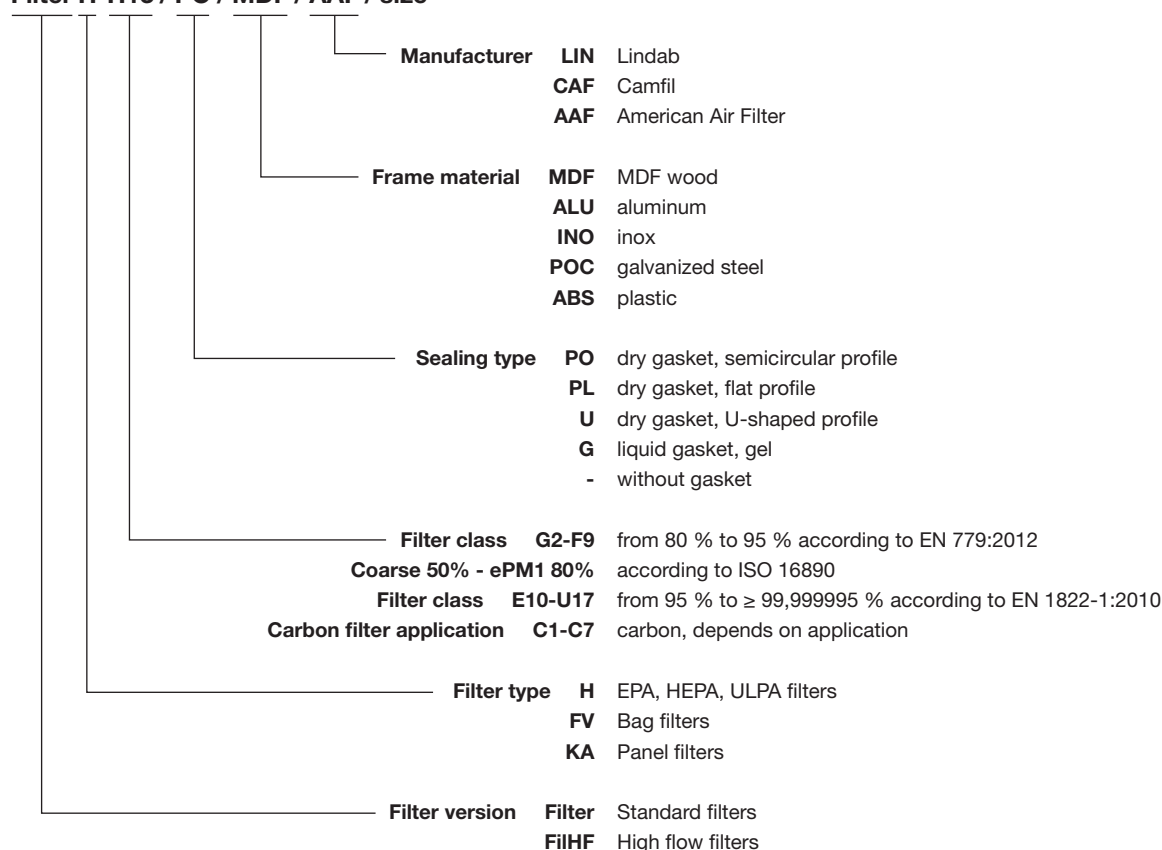

# Accessories



AF-01/001  
DPS key lock



AF-01/002  
FR key lock



AF-02/001  
Mark II pressure gauge



AF-02/002, AF-02/003,  
AF-02/004, AF-02/005,  
AF-02/006  
Magnehelic pressure gauge



AF-02/007, AF-02/008,  
AF-02/009  
Photohelic pressure gauge



AF-02/010, AF-02/011  
Digihelic pressure gauge



AF-02/012  
Digihelic (3-in-1) pressure gauge



AF-03/001  
02/002-02/006 pressure gauge holder



AF-03/002  
02/007-02/011 pressure gauge holder



AF-04/001, 04/002, 04/003  
Pressure switch

Table 1: Pressure gauge table

Technical Data	AF-02/001	AF-02/002, AF-02/003, AF-02/004, AF-02/005, AF-02/006	AF-02/007, AF-02/008, AF-02/009	AF-02/010, AF-02/011	AF-02/012
Description	Mark II pressure gauge	Magnehelic pressure gauge	Photohelic pressure gauge	Digihelic pressure gauge	Digihelic (3-in-1) pressure gauge
Type Accuracy	analogue ±3 % full scale	analogue ±2 % full scale	Analogue ±2 % full scale	Digital ±0.5 % at 25 °C	Digital ±0.5 % at 25 °C
Pressure range	10-0-700 Pa	AF-02/002 ... 0-250 Pa AF-02/003 ... 0-500 Pa AF-02/004 ... 0-750 Pa AF-02/005 ... 0-1000 Pa AF-02/006 ... 0-1500 Pa	AF-02/007 ... 0-500 Pa AF-02/008 ... 0-750 Pa AF-02/009 ... 0-1000 Pa	AF-02/010 ... 0-622.75 Pa AF-02/011 ... 0-1245.5 Pa	0-1245 Pa
Pressure connection	1/8" female NTP	1/8" female NTP	1/8" female NTP	1/8" female NTP	2 male NTP 1/8" plugs for tube ø4 up to ø6
Standard accessories	2 male NTP 1/8" plugs for tube ø4 up to ø6	2 male NTP 1/8" plugs for tube ø4 up to ø6	2 male NTP 1/8" plugs for tube ø4 up to ø6	2 male NTP 1/8" plugs for tube ø4 up to ø6	/
Temperature range	max. 60 °C	-6.67 to 60 °C	-6.67 to 60 °C	0 to 60 °C	0 to 60 °C
Housing material	ABS plastic	die cast aluminum case	die cast aluminum case	die cast aluminum case	ABS plastic
Electrical connection	/	/	8 wire cable	male 15 pin d-Sub	screw terminals
Operative voltage	/	/	24 VDC±10 %	12-28 VDC or 12-28 VAC 50-400Hz	<b>High voltage power:</b> from 100 to 240 VAC 50 to 400 Hz or from 132 to 240 VDC <b>Low voltage power:</b> 24 VDC ±20 %
Relay	/	/	<b>Switch type:</b> each setpoint has a solid state relay <b>Switching voltage:</b> 20-280 VAC (47-63 Hz) <b>Switching current:</b> 0.01 – 1 A	<b>Switch type:</b> 2 SPDT relay <b>Electrical rating:</b> 1 A @ 30 VAC/VDC	<b>Switch type:</b> 2 SPDT relay <b>Electrical rating:</b> 8 A @ 240 VAC
Agency approvals	/	/	CE	CE	CE, UL
Communication	/	/	/	/	Modbus® RTU, RS485, 9600 baud.
Output	/	/	/	4-20 mA DC into 900 ohms max.	4-20 mA DC into 900 ohms max.

Table 2: Pressure switch table

Technical Data	AF-04/001	AF-04/002	AF-04/003
Description	Pressure switch	Pressure switch	Pressure switch
Type	QBM81-3	QBM81-5	QBM81-10
Accuracy	< ±2.5 Pa	< ±5 Pa	< ±10 Pa
Pressure range	20...300 Pa	50...500 Pa	100...1000 Pa
Pressure connection	Male, ø 6.2 mm	Male, ø 6.2 mm	Male, ø 6.2 mm
Standard accessories	/	/	/
Temperature range	- 30 ... + 84 °C	- 30 ... + 84 °C	- 30 ... + 84 °C
Housing material	Polycarbonate, PVC, ABS	Polycarbonate, PVC, ABS	Polycarbonate, PVC, ABS
Electrical connection	3 screw terminals	3 screw terminals	3 screw terminals
Operative voltage	/	/	/
Relay	<b>Switch type:</b> single-pole change-over Switching voltage and current: AC/DC 24 V ≥ 0,01 A AC 250 V, ≤ 5 (0,8) A	<b>Switch type:</b> single-pole change-over Switching voltage and current: AC/DC 24 V ≥ 0,01 A AC 250 V, ≤ 5 (0,8) A	<b>Switch type:</b> single-pole change-over Switching voltage and current: AC/DC 24 V ≥ 0,01 A AC 250 V, ≤ 5 (0,8) A
Agency approvals	CE conformity to (Low-voltage directive 2006/95/EC)	CE conformity to (Low-voltage directive 2006/95/EC)	CE conformity to (Low-voltage directive 2006/95/EC)
Communication	/	/	/
Output	/	/	/

Picture 1: Pressure switch function diagram and connection terminals

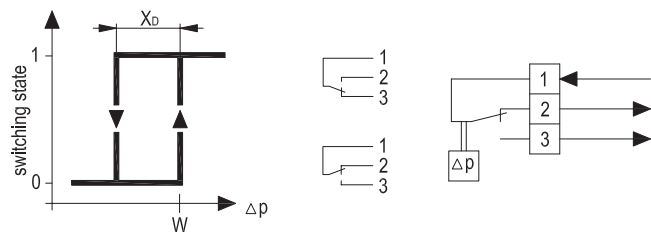

**Legend:**

- 1** Phase
- 2** Switch position 1-2: lower pressure
- 3** Switch position 1-3: higher pressure
- X<sub>p</sub>** Switching difference
- Δp** Pressure difference
- W** Switching point, top

**Ordering key**

**AF - 01 / 001**

└───┬───	<b>Keys for locks</b>	<b>01/001</b>	DPS
		<b>01/002</b>	FR
	<b>Pressure gauge</b>	<b>02/001</b>	Mark II
		<b>02/002</b>	Magnehelic 0-250 Pa
		<b>02/003</b>	Magnehelic 0-500 Pa
		<b>02/004</b>	Magnehelic 0-750 Pa
		<b>02/005</b>	Magnehelic 0-1000 Pa
		<b>02/006</b>	Magnehelic 0-1500 Pa
		<b>02/007</b>	Photohelic 0-500 Pa
		<b>02/008</b>	Photohelic 0-750 Pa
		<b>02/009</b>	Photohelic 0-1000 Pa
		<b>02/010</b>	Digihelic 0-622.75 Pa
		<b>02/011</b>	Digihelic 0-1245.5 Pa
		<b>02/012</b>	Digihelic (3-in-1) 0-1245 Pa
	<b>Holders for pressure gauges</b>	<b>03/001</b>	02/002 – 02/006
		<b>03/002</b>	02/007 – 02/011
		<b>03/003</b>	02/012
	<b>Pressure switches</b>	<b>04/001</b>	SI QBM81-3 (20-300 Pa)
		<b>04/002</b>	SI QBM81-5 (50-500 Pa)
		<b>04/003</b>	SI QBM81-10 (100-1000 Pa)

**Note:**

- When choosing pressure gauge you have to connect it with ø6/ø4 tube.







## Good Thinking

**At Lindab** we simplify construction for our customers. We do that by designing easy-to-use products and solutions, as well as offering efficient availability and logistics. We are also working on ways to reduce our impact on our environment and climate. We do that by developing methods to produce our solutions using a minimum of energy and natural resources, and by reducing negative effects on the environment. We use steel in our products. It's one of few materials that can be recycled an infinite number of times without losing any of its properties. That means less carbon emissions in nature and less energy wasted.

**We simplify construction**